

# Restoration of an Eddystone's 'One and Only HiFi Separate' – Model S.820 Tuner - by Gerry O'Hara, G8GUH

## Background

When I joined the EUG, Graeme Wormald sent me several issues of Lighthouse and a copy of the excellent Quick Reference Guide (QRG), 2<sup>nd</sup> Edition as part of my 'hazing' (this document can now be downloaded from the EUG web site). While browsing this very commendable tome authored by Graeme, I noticed what I thought was a bit of an oddity on page 34 under the section entitled 'The Small Valved Eddystones': first up under that section was 'Eddystone Type S.820 1955-58. Broadcast HiFi FM Tuner...' I was quite intrigued. Eddystone made a HiFi tuner? – that was news to me, and I wondered why they did so – this being an apparently significant departure in direction, even in the 1950's when Eddystone had a retail outlet ('Webb's Radio' located at 14, Soho Street, London, W1) and their business model included manufacturing sets for the radio amateur and domestic short wave listener market as well as for professional and military applications.

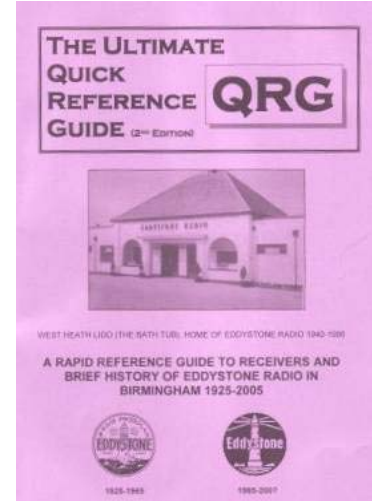

The S.820 was noted to cover the (then) FM Band from 87.5 -100MHz (mono) plus one 'Long Wave' and two 'Medium Wave' (Broadcast Band) channels as presets. The EUG description goes on to note that the tuner was supplied without a case, it being meant for custom mounting in a 'HiFi' console, as was in vogue at the time. The model reportedly had a production run of only 1000 units and cost some £38 (including a monstrous £9.50 'purchase tax' – see later): not an insignificant sum in 1955. The model sported a tuning mechanism based on the famous Model No. 898 dial sold by Eddystone as a DIY item to radio constructors (which alone I have seen raise over £50 on EBay), and was an 8 valve circuit complete with its own mains power supply. My appetite was wetted and I decided that I had to have one when the opportunity arose – it looked cute, was an oddity in the Eddystones line-up and I was curious as to what one would sound like when played

through a reasonable sound system. Besides, it would make a nice set to provide background music while working in my shack...



A couple of years went by – monitoring EBay and locating all the S.820 references in the EUG Newsletter and the Lighthouse magazine – and then an S.820 finally came up for auction in Washington DC, USA (good for me – less

The S.820 on arrival – not bad at first glance

shipping charges than from the UK to my home in the Vancouver area, Canada). It looked in reasonable shape in the advert: a few valve screens missing but otherwise good. So I bid and was amazed to pick it up for only \$43 (about £21).



**The EDDYSTONE '820'**  
V.H.F. (F.M.)  
Sound Receiving Unit

*Clarity  
Fidelity  
Range*

Designed for reception of V.H.F. (F.M.) transmissions; also for one preset long wave station and two preset medium wave stations. The '820' is of advanced design, precision built using first-class materials. It is a product of Stratton & Co. Ltd., who enjoy a World-wide reputation for Communication equipment of the highest standard.

**OPERATION**  
Continuum tuning is available over Band II and the horizontal dial is clearly marked in frequency. It is a simple matter to tune straight on to the desired station. Full sweep adjustment built shown by maximum expansion of the glow in the frequency tuning indicator. Your dealer will set up the preset medium and long wave positions in accordance with locally available stations. The frequency dial is marked with the call letters of the stations. All necessary adjustments may be made on the signals from the desired station, if these are fairly strong.

**GUARANTEE**  
The Eddystone '820' receiving unit is guaranteed against faulty workmanship or component breakdown for a period of 12 months from date of purchase. The owner is covered by the normal guarantee issued by the British Radio Valve Manufacturers' Association.

It is only necessary to turn the switch to one or other of the indicated positions, and adjust the volume to suit.

List Price £38 : 0 : 0 (INCLUDING PURCHASE TAX @ 10 : 0)

22-9-16-0

Manufacturers:  
**STRATTON & CO. LTD.**  
BIRMINGHAM 31 :: ENGLAND  
Telephone: PRIORY 2231 Cables: STRATHOOD, BIRMINGHAM

MANUFACTURERS OF SPECIALISED SHORT WAVE RADIO EQUIPMENT SINCE 1925

Printed in England

A couple of weeks later it duly arrived in British Columbia, very well packed, and complete with an original leaflet and instruction manual. The leaflet (scan appended to this article) has both the price and the amount of tax payable printed on it as well as a hand-written price scribbled on the back – looks like the wily purchaser managed to negotiate a decent discount from Webb's...? My set is Serial No. FG0020, which dates it as being manufactured in June 1955, and this date ties in with the May 1955 date marked on the can of the smoothing capacitor. Looks like mine is a very early model – so early that the folks at the Bathtub seem to have forgotten to indicate the model number on the rear of the tuning dial as shown on the illustration in the QRG, the leaflet and the instruction book.

During my two year gestation period I started to look at the evolution of HiFi following WWII, albeit with only a passing interest, but in my younger days I was always in awe of audio equipment manufactured by British manufacturers like Quad and Leak – it just looked right, was solid, well-made and they tended to have neat and well thought-out wiring (just like most Eddystones) – I recall servicing a Leak amplifier in my days at Mysons in Carlisle in the early 1970's and being impressed by the neat wiring. I will not digress too much on this topic, but the following section compares the S.820 with a couple of its contemporaries and a few web links are provided at the end of this article if anyone is interested in taking more of a look. What I did note was that some of the equipment manufactured by those names in the 1950's can command very high prices these days – for example a (mono) Quad II power amp can top \$1,000. So why did Eddystone decide to manufacture a HiFi tuner? and what was the market the S.820 was launched into like? How sophisticated were HiFi set-ups at the time? and, in particular, what was the status of quality radio reception in the UK in the 1950's? So I thought that it would be interesting to take a brief look at the market the S.820 was entering, including a peek at some of its competition and/or peers before I go on to describe bringing my set back to a serviceable and cosmetically good condition.

### Context of the S.820

So why introduce an FM tuner into the Eddystone range in mid-1955? I would say that it was because there was a great (apparent) opportunity opening up due to the BBC introducing new services in the UK and the 'HiFi' bug was just catching on: more and more homes were acquiring radio and audio equipment that was capable of providing very good quality reproduction and there was a fledgling 'high-end' market developing

for the more 'well-heeled' listener. The sidebar to the right provides some interesting background details of the status of FM broadcasting in 1950's Britain for the interested reader<sup>1</sup>.

And what was some of the competition like?

In the UK, the 'Leak' brand of HiFi equipment had launched their 'Trough-Line' (MkI) tuner around the same time (1955) as the S.820 made its debut. The Trough-Line's main design/selling feature was a very stable oscillator circuit using a tapped transmission line formed by a metal trough surrounding the resonant element. This unit was also supplied without a case, being meant for inclusion in a console. A good description of this unit appeared in a



Above; an early Leak Trough-Line FM tuner with the pressed steel front, dating between 1955 and 1959.

contemporary issue of "HiFi News":

*"Leak have adapted for their oscillator, a variation on the quarter-wavelength line type of resonator. It has been found in communications engineering that for frequencies in the 100Mc/s region and*

#### Status of FM Broadcasting in the UK During the 1950's

*The first of the BBC's new Band II VHF FM radio transmissions started on May 2nd 1955 from the new mast at Wrotham, Kent. This new service brought high fidelity radio to around 13 million potential listeners in London and the South East from the Home 93.5 MHz, Light 89.1 MHz and Third Programmes 91.3 MHz. The FM mode of transmission was broadcast on VHF frequencies between 88.0 MHz and 95.0 MHz and was less susceptible to the types of interference often encountered on medium and long waves which used the AM mode of transmission. This fact coupled with the ability to use a higher bandwidth which could provide 'Hi-Fi' quality transmission and reception enabled the BBC to offer the then three radio services, Home, Light and Third with audio quality never before experienced by listeners. All transmissions were initially in mono however.*

*The BBC opened further high power VHF FM radio transmitters in December 1955. For the West of England and South Wales from the Wenvoe transmitter (120 kW) was opened and transmissions for the North East from Pontop Pike (60kW) commenced. In 1956 Sutton Coldfield (Midlands - 120 kW), Holme Moss (North - 120 kW), North Hessary Tor (South West - 60 kW), Tacolneston (East - 120 kW), Kirk O' Shotts (Central Scotland - 120 kW), Meldrum (North East Scotland - 60 kW) and Divis (Northern Ireland - 60 kW) followed. A transmitter at BlaenPlwyf (60 kW) was also installed to bring reception to the Cardigan Bay area along with a temporary transmitter in the Anglesey area where reception on the Welsh Home service was particularly poor.*

*More high power main-stations were soon introduced followed by many low power relay stations that filled in some significant pockets of poor reception [hence Eddystone hedging their bets by including some pre-set AM capability to allow users to tune in to their favourite programs in this mode until they became available on VHF FM], and in January, 1958 the BBC commenced experimental stereo transmissions on VHF FM in the London area. In the USA, radio station WGFM in Schenectady, New York and station WEFM Chicago were transmitting the first regular programmes in FM stereo in June 1961 using the Zenith GE Pilot Tone System and the BBC commenced permanent VHF FM stereo radio broadcasting of the Third Programme in August 1962 from the Wrotham transmitter using the same technology on 91.3 MHz. Stereo broadcasting was very gradually rolled out across the BBC's network of VHF transmitters and national radio stations from the 1960's until the 1980's.*

<sup>1</sup> Edited excerpt from 'UK Radio – A Brief History Part 2, Post War' on Mike Smith's very informative site <http://www.arar93.dsl.pipex.com/mds975/Content/ukradio2.html>

above, it becomes increasingly difficult, for a multitude of reasons, to make the conventional coil and condenser combination operate satisfactorily; the chief among these reasons are the capacitance inherent in the coil, and the inductance in the condenser. Now, a quarter-wavelength section of transmission line, shorted at one end, behaves as a parallel resonant circuit of very high  $Q$  and electrical stability, while the mechanical construction of such a device leads almost automatically to great rigidity (and hence stability). The  $Q$  being high, tapping down will still permit adequate voltage at the output; and as the coil is a straight piece of wire, selection of optimum tapping points is obviously much facilitated. Below is a diagram of the resonator in the Leak circuit, and also the bread and butter version. It is clear that the Leak resonator is not a true quarter-wavelength section, its length being under 6 inches, but its frequency in the Trough-Line is controlled by added (variable) capacitance."

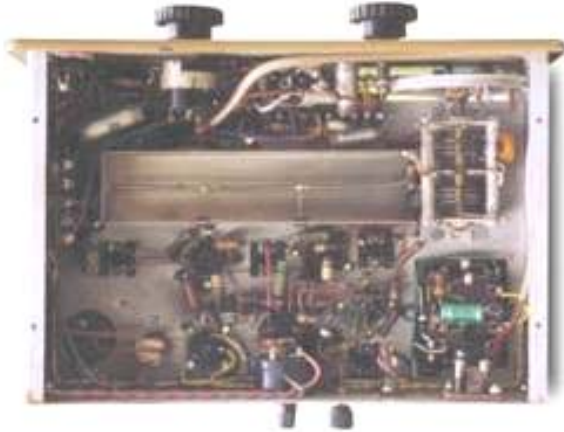

Can you spot the Trough-line on this Mk1 Leak chassis?

Other details given in the review for the MkI Trough-Line are:

- Frequency Range: 88-100MHz.
- Foster-Seeley discriminator circuit.
- Magic eye tuning indicator, 2kHz accuracy.
- 10lbs weight.
- Self powered (like the Eddystone S.820) – quite a selling feature as it meant less of an installation effort unlike many other British tuners of the time that required HT and LT power to be supplied from the audio amplifier they were being used with.
- Valve/tube complement (8) was as follows: EM81 (magic-eye tuning indicator), EB 91, 2 x EF80, 3 x ECF80, EZ80 (rectifier).

The MkI Trough-Line was replaced by the MkII around 1958. This model had a quoted

great rigidity (and hence stability). The  $Q$  being high, tapping down will still permit adequate voltage at the output; and as the coil is a straight piece of wire, selection of optimum tapping points is obviously much facilitated. Below is a diagram of the resonator in the Leak circuit, and also the bread and butter version. It is clear that the Leak resonator is not a true quarter-wavelength section, its length being under 6 inches, but its frequency in the Trough-Line is controlled by added (variable) capacitance."

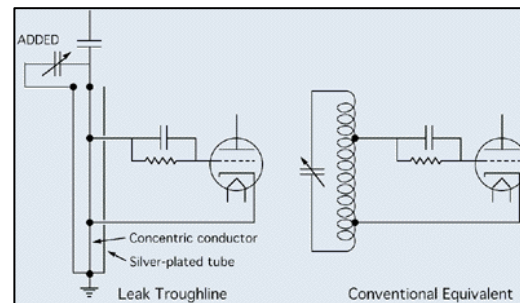

Above: Trough-line versus conventional components. Below: above chassis view of the Mk1 Troughline – a bit flimsey eh?



drift of 15kHz without its AFC switched on and with the AFC circuit switched on this was reduced to 3kHz drift (or approx 0.003%). The published specification for the MkII Trough-Line includes the following:

- Frequency Range: 88-108 Mhz (note the extended upper end of the band from 100MHz to 108MHz).
- 2 microvolt sensitivity for full limiting.
- 300 Ohms or 75 Ohms aerial input.
- Cathode follower audio output.
- Multiplex output for add-on stereo decoder.
- Valve/tube complement (7) was as follows: 2x ECF80/6BL8, ECC84/6CW7, ECC85/6AQ8, EF80/6BX6, EM84/6FG6 (magic-eye tuning indicator), EZ80 (rectifier)



The MkII Trough-Line was originally issued as a mono unit, with provision for adding a stereo de-multiplexer later. Subsequent models were also available with solid-state stereo decoders. As in the Leak, no provision was made in this range for AM reception.

Build-quality of the Leak units seems to have been good, though they do look a bit 'lightweight' when compared with the Eddystone unit – mind you, most things do.



Another famous name in British HiFi, Quad, also introduced their 'FM Tuner' (photo, left) around the same time (referred to as the 'FM1', presumably to distinguish it from the later 'FMII'). Although the Quad FM Tuner did not cover the AM bands (perhaps its name was a bit of a give-away in this regard), Quad also made a matching AM-only tuner for this specific purpose. These units were not fitted with

their own power supplies, however, deriving their LT and HT supplies from the amplifier units they were used with. They were therefore much lighter (less than half the weight of the Eddystone and Leak tuners) and were built into 'sleeker' looking cases, although the mechanical build quality cannot light a candle to that of the Eddystone (at least in my book) being reminiscent of a cheapo 'all-American 5' chassis – refer to the photo, top of next page. Even so, Quad's cosmetic style is a design classic that I have to admire.

Earlier Quad FM1's were badged 'Acoustical', later ones 'Quad'. Later models included an internal switch for use of the Quad stereo decoder. The early Quad tuner valve line-up was 6BH6, 12AT7, ECC81, 6BJ6, 6BH6, 6AU6, 6AL5/EB91, 12AX7/ECC83

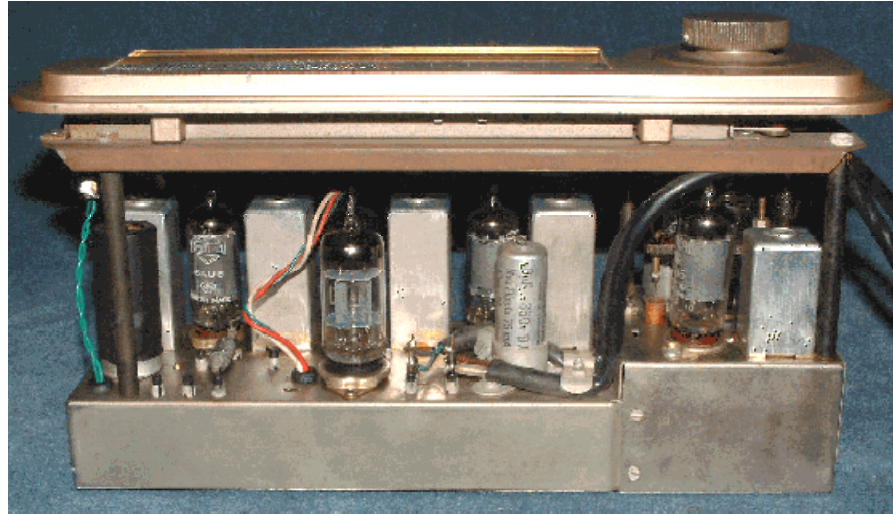

(the 6AU6 was replaced by a 6BH6 at some point in the production cycle).

I have included circuit diagrams for the Leak and Quad tuners in an Appendix to this article for comparison to the S.820 circuit (also appended). The Quad tuner circuit somewhat resembled the S.820 in its FM configuration, apart from a novel twin-light tuning indicator circuit in the Quad (photos, right) and provision of an output for connection of a stereo decoder, whereas the Leak's circuit design was rather more sophisticated for its day, featuring a cascode RF amplifier and a cathode-follower AF stage, the use of the trough-line tuning element (incorporating a switchable AFC), output for a stereo decoder and it used solid-state diodes in the discriminator circuit.

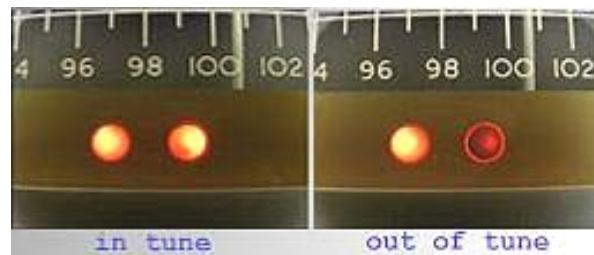

So why were only some 1000 S.820's ever built in its three year production period lasting from 1955 to 1958? and why did Eddystone not follow in the footsteps of Leak, Quad and others in improving on their original offering, eg. adding features such as a cascode RF stage, AFC, stereo decoder and the like? I don't know, other than speculate that the competition was too specialized and focused directly into that particular sector of the electronics market place, where cosmetic appearances and 'hype' were almost as important as the quality of the electronic performance. Also, perhaps the 'classic' 1950's Eddystone style of the S.820, adapted from their successful contemporary ranges of communications receivers, did not 'cut the mustard' in living rooms where it was under the fickle-eye of non-technical family members? - come on Bill, spill the beans...

### **A Look at the S.820 Circuit and Features**

Wireless World published a review of the S.820 in their July, 1955 issue (copy appended to this article) that included a very good description of the circuit. In essence, the circuit comprises virtually 'textbook' building-blocks. In VHF (FM) Mode:

- The aerial is connected to a tuned-grid pentode (6AM6) RF Amplifier choke capacitance coupled to the tuned-grid of
- A dual-triode (12AT7), one half acting as a mixer, the other half as the local oscillator at VHF, feeding to a double-tuned 10.7MHz IF transformer, the secondary of which connects through the band-change switch to the tuned-grid of the hexode section of
- A triode-hexode (ECH42), which in this mode functions as the first IF amplifier (the triode section of this valve being rendered inoperative in this mode), the hexode anode couples through a second double-tuned 10.7MHz IF transformer to the grid of
- A pentode (6AM6) second IF amplifier coupling through a third double-tuned 10.7MHz IF transformer to the grid of
- A pentode (6AM6) limiter, the anode circuit of which contains the primary of the discriminator transformer, the secondary of which is connected to the anodes of
- A dual-diode (6AL5) connected in a Foster-Seeley circuit, the output of which is connected through a wafer of the waveband switch (here selecting the discriminator output) to the audio output connector - a Belling-Lee coax connector - via the volume control.
- A 'magic-eye' (EM80) tuning indicator, the grid of which is connected to the input of the limiter valve; and it is worth noting that
- There is no automatic frequency control (AFC) circuitry fitted and the band selector switch derives AGC from the limiter stage grid bias to control gain of both IF amplifier valves in this mode.

And in the (pre-set) AM Mode:

- The VHF RF amplifier and mixer oscillator are disconnected from the grid of the hexode section of the triode-hexode (ECH42), this instead being connected to the broadcast band (2 x MW and x LW) preset antenna tuned circuits via the band change switch.
- The triode section of the triode-hexode acts as the local oscillator, the output of which is internally coupled to the hexode section of the ECH42 producing an IF of 465KHz at its anode. A double-tuned 465KHz IF transformer is located in its anode circuit (in series with the 10.7MHz IF transformer), passing the IF signal to the grid of
- The pentode (6AM6) IF amplifier, again having a double-tuned 465KHz IF transformer in its anode circuit (also in series with the corresponding 10.7MHz IF transformer).
- The IF signal at the secondary of the second 465KHz IF transformer is



- demodulated by a GEX34 germanium diode and the resultant audio fed to the audio output connector via the volume control; and
- AGC is also derived from the GEX34, this being used to control gain of both the mixer and the IF amplifier valve when the tuner is working in AM mode. The 'magic-eye' is inoperative on AM.

A simple full wave rectifier power supply with an EZ41 coupled to a resistance-capacitance filter is used to supply the 205v HT to the tuner.

### Preliminary Inspection and Safety Checks

Out of the packaging, first impressions were that the set was as it appeared on the EBay advert. Then I set it on the bench and noticed it did not sit square, then I saw that the flexible coupler between the tuning dial drive shaft and the tuning capacitor gang was operating at a really wild angle (photo, right) and was offset sideways – oh dear, I realized that I now owned yet another 'dropped Eddystone' (refer to my other articles for discussion on this issue). The quality of the packing (double boxed with bubble wrap galore) suggested that it was probably like that before shipping to me. Oh well, what can I expect for \$43? I decided that I had to straighten the chassis out as a priority - enough at least to allow the tuning shaft to align properly with the capacitor gang. I also noticed that the screen retaining collars on two of the valve bases were broken (one completely loose) and that some of the screening cans were missing when compared to the photo on the front of the manual supplied with the radio.



But first though, I noticed that the mains connector did not have a ground wire and that there was no fuse fitted. I also noted that there was no 120v tap on the power transformer, so I would need to use an autotransformer unless I replaced the transformer (which I did not want to do). Feeling uneasy about all of this, I installed a fuseholder fitted with a one amp fuse under the chassis (photo, right) and replaced the power cord with one that included a ground wire,

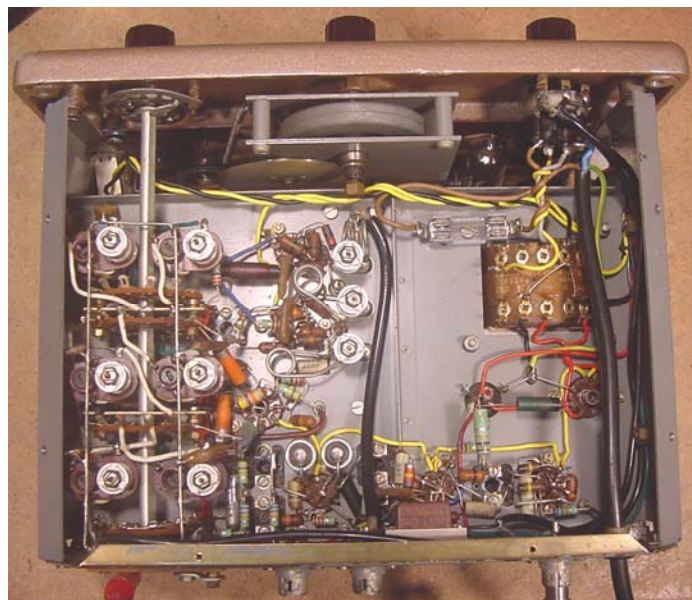



connecting the ground wire to the chassis ground point near the smoothing capacitor can.

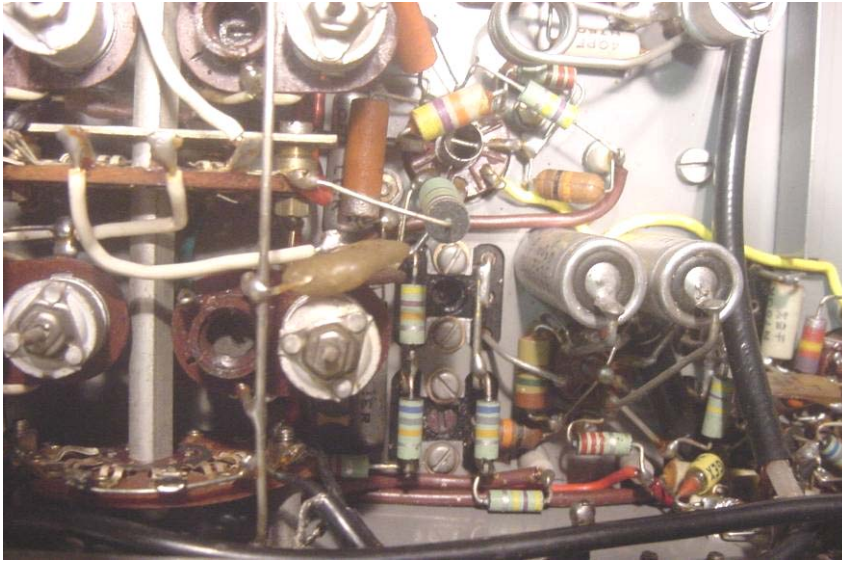

You will see from the photos that the quality of the wiring is first-class and is comparable to that found on contemporary Eddystone professional-grade communications receivers (eg. 730/4), with superlative 'regimental' wire dressing and component layout.

### Front Panel Removal and Replacement

The S.820 utilizes a modified form of the Eddystone catalogue No. 898 dial (example in photo, right), this being mounted on the cast aluminium front panel, which is in turn bolted to the two chassis side-plates. The chassis itself is grey-painted brass.

Removal of the front panel in this simplified form of 'traditional' Eddystone construction is very straightforward. Here is the recipe:



- Remove the knobs (on my set the grub screws stubbornly refused to move, so I poured a little WD-40 into the screw-holes and left it there for a couple of hours. The screws loosened ok after that);
- Carefully remove the finger-plate, clean with soapy water and store safely (the finger plate was stuck onto the front panel casting with some tarry compound as it is otherwise only secured by the volume control bushing nut);
- Loosen two screws in the flexible coupler on the tuning gang shaft;
- Remove the four 2BA bolts securing the chassis side plates to the front panel; and
- Gently pull the front panel away from the chassis (photos, top of next page and on page 11).

The next job is to dismantle the No. 898-type mechanism sufficient to allow cleaning and lubrication, as well as access to the scale glass for cleaning:

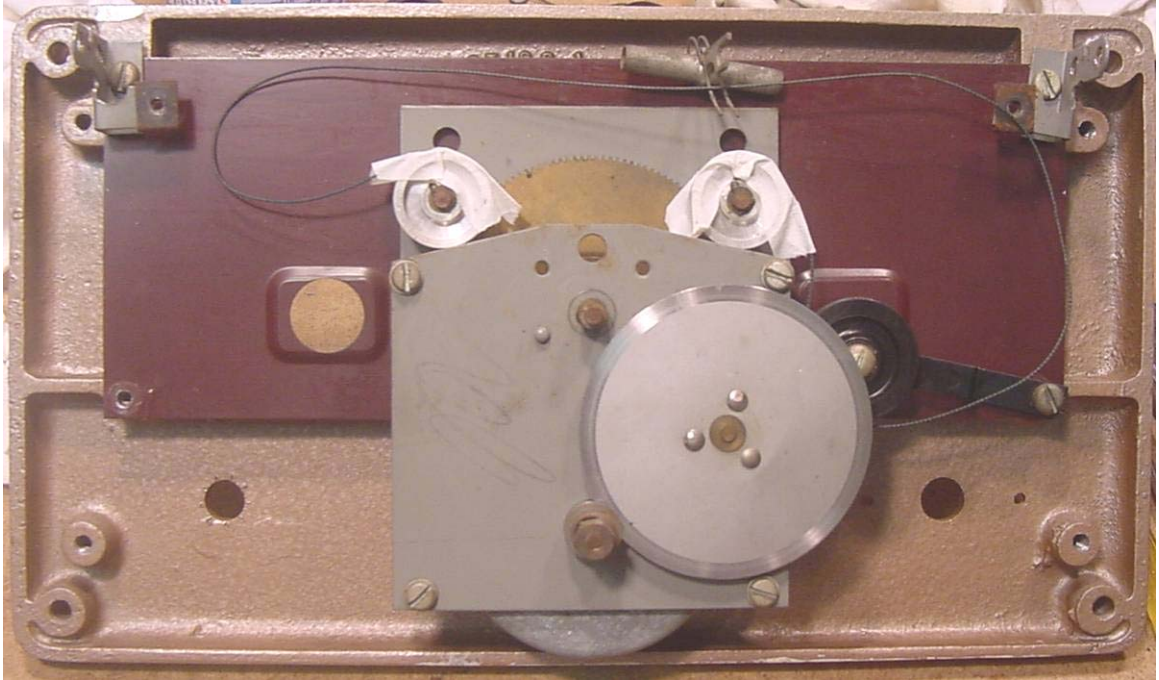

- Place small pieces of masking tape on the spool pulleys to retain the drive cord in place (photo, above);
- Remove the two pointer guide rails by levering-off the retaining springs from either end. This allows access to;
- Remove the two idler pulleys at each end of the dial cord run. Also remove the spring-loaded cord tensioner pulley;
- Remove the three screws securing the No. 898 drive mechanism to the front panel - be careful as each has a split washer between the No. 898 gearbox plate and the rear of the front panel – don't lose them;
- Pull the gearbox away from the front panel;
- Unscrew the three remaining screws securing the rear (brown) plate from behind the dial glass, noting how the two cheek plates are secured. Pull the plate away, revealing the dial glass; and

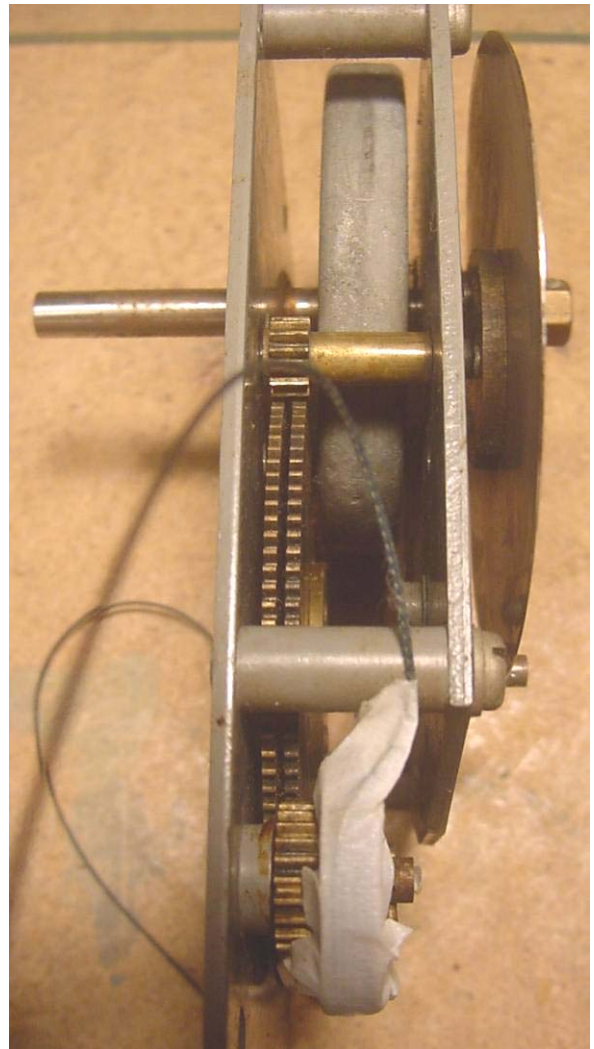

- Carefully remove the dial glass (it may be tacked in place using some of the black tarry compound similar to that used for the fingerplate – mine was).

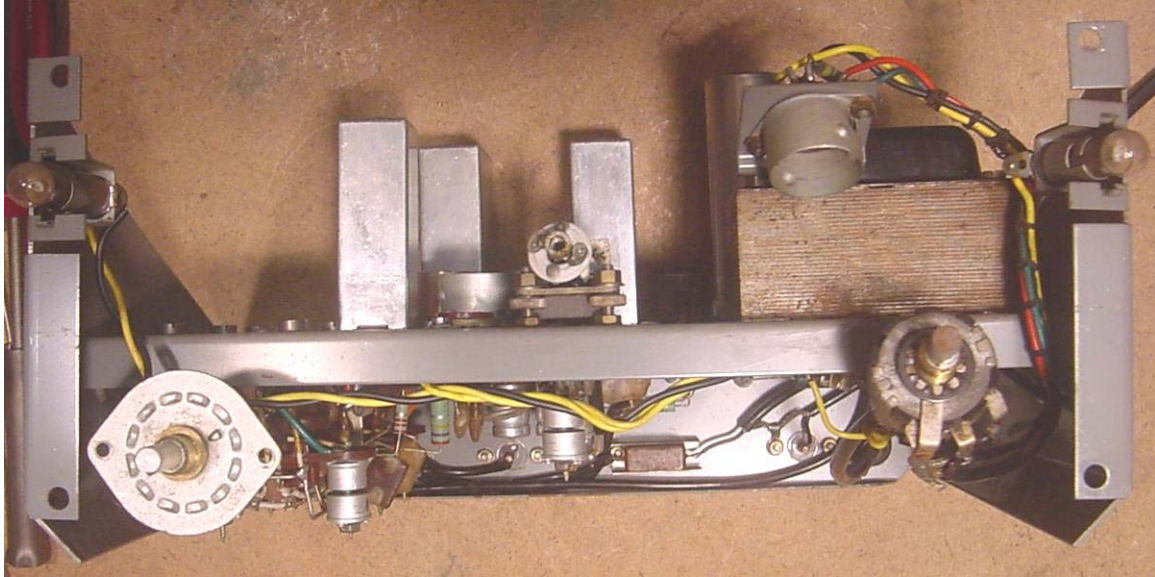

Take this opportunity to carefully clean the dial glass with luke-warm slightly soapy water (even being extremely gentle, a few small flakes of the dial paint came away when I was cleaning the slight nicotine grime off the inside of mine). Also clean the brown rear plate and matching cheek plates. This is also a good time to clean hardened oil/grease from the gearbox bearings and gears (photo, previous page) and to re-lubricate with suitable grease (I used a sparing amount of Moly-grease). Clean the friction clutch mechanism and ensure the drive plate is grease-free.

Re-assembly is simply a reversal of the above, taking care to ensure that the dial cord is threaded as per the original (tip - take a few photos and/or sketch it before you start dismantling for reference). Attachment of the pointer to the dial cord can be a bit fiddly – refer to the photo, below, right to see how it is done.

While dismantled, I noticed that the front panel on my set is slightly warped (as well as the chassis itself). Concerned that the aluminium casting might fracture if I attempted to straighten it, I decided to leave it alone and instead just try to straighten the chassis. This was done by applying 'strong-arm tactics' – I managed to straighten it sufficiently to allow the tuning gang shaft to align reasonably well with the No. 898 drive shaft (photo, right).

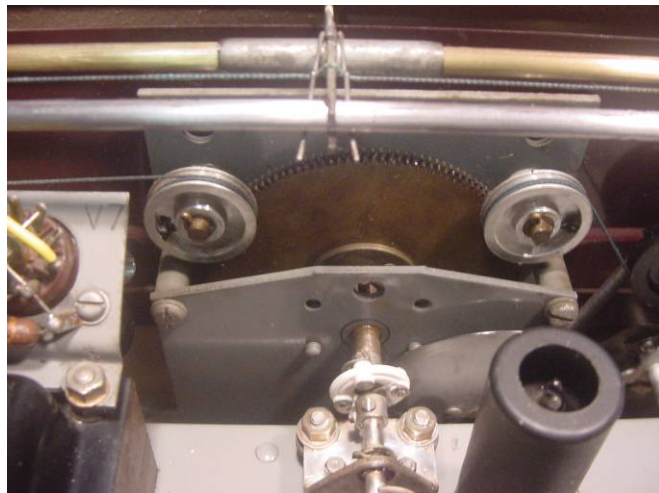

### Initial Clean-up and Power-on

The tuning capacitor gang is silver-plated and this was carefully cleaned with 'Silvo' to improve its cosmetic appearance and the contacts then cleaned with De-Oxit and the ball bearing re-packed with Moly-grease. The tuning pointer guide rails were lightly smeared with Moly-grease, as was the bandchange switch indents. The contacts on the bandswitch were carefully cleaned with De-Oxit and a squirt of this fluid was also sprayed into the volume control.

A few continuity checks were undertaken with the new mains lead fitted – the on-off switch (ganged with the volume control) seemed to work well and other checks seemed ok, so I decided that it was time for initial power-on checks:

- I removed all the valves, cleaned and checked them on my Precision valve tester – they tested good to very good. I suspect that they may even be the original fitment as they are all either Osram or Mullard, made in the UK (if that is the case, the tuner has probably seen very little service in its 52 year lifetime – a bit like me...);
- Checked the resistance measurement from HT to chassis – rather low, rising to only around 2kohms after an initial dip to almost zero on the meter as the smoothing capacitors charged up. I decided that I would re-form the power supply electrolytic capacitors in-situ;
- I attached an AC voltmeter across the power transformer HT secondary, coupled up the power lead to my variac and gradually applied power. The voltmeter indicated that the HT winding was good and so the LT windings were checked – also ok;
- Switched off the power and re-installed the rectifier (EZ41). Connected a DC voltmeter on its 300v range across the HT line and the chassis. Re-applied power gradually using the variac and at around 60 volts AC applied to the transformer primary, some DC voltage began to appear across the twin smoothing capacitors (C65); the capacitors were re-formed over a couple of hours by slowly increasing the applied AC voltage from the variac, monitoring the HT current draw (all valves still removed except the rectifier) - increasing the voltage in stages, holding for up to 15 minutes and also switching off/on a couple of times at each stage. I increase the applied voltage in increments of 25v, up to the full HT volts of ~205v DC. Leakage current at the end of re-forming exercise was acceptably low on all capacitors – impressive for 52 year old units. I noticed that the 'magic-eye' had been left plugged in and it was glowing quite nicely



- (photo, bottom of previous page);
- Undertook leakage checks on a few of the 'TCC' metal-can 0.01uf and 0.1uf tubular paper HT and screen by-pass capacitors (C3, C7, C19, C26, C42, C43 and C55), and AGC line capacitors (C27, C33, C46) – those tested appeared ok, so I decided to try powering-up the set without replacing any;
  - Checked the HT smoothing resistor (R36) and a couple of the anode load resistors – all seemed within tolerance, so I;
  - Re-installed the remaining valves, connected short aerials to the AM and FM aerial connections and attached a (powered) computer speaker set to the AF output. Slowly brought the set up on the variac over around 15 minutes, monitoring the HT voltage;
  - After about 29 seconds...nothing. I switched off quickly and started to investigate – nothing obviously wrong, so I switch it back on, turning the amplified speaker volume to maximum. I could hear hum and a slight hiss, controllable using the volume control on the S.820. The set was switched to FM during these tests. I switched to one of the AM positions – more noise appeared. I then tuned one of the MW local oscillator pre-set capacitors and voila! - a station came in on 1410kHz. Still nothing on FM though.
  - I did a few voltage checks using the table in the manual as a guide (I used a homebrew 1000ohm/volt meter adapter that allows quick switching-in of the correct range shunts – see the sidebar on page 13 of my S.750 restoration article) – the AM section was fine, as was the RF amplifier in the VHF section, but there was no anode voltage on the mixer (12AT7). The anode load resistor (R4) had checked out ok

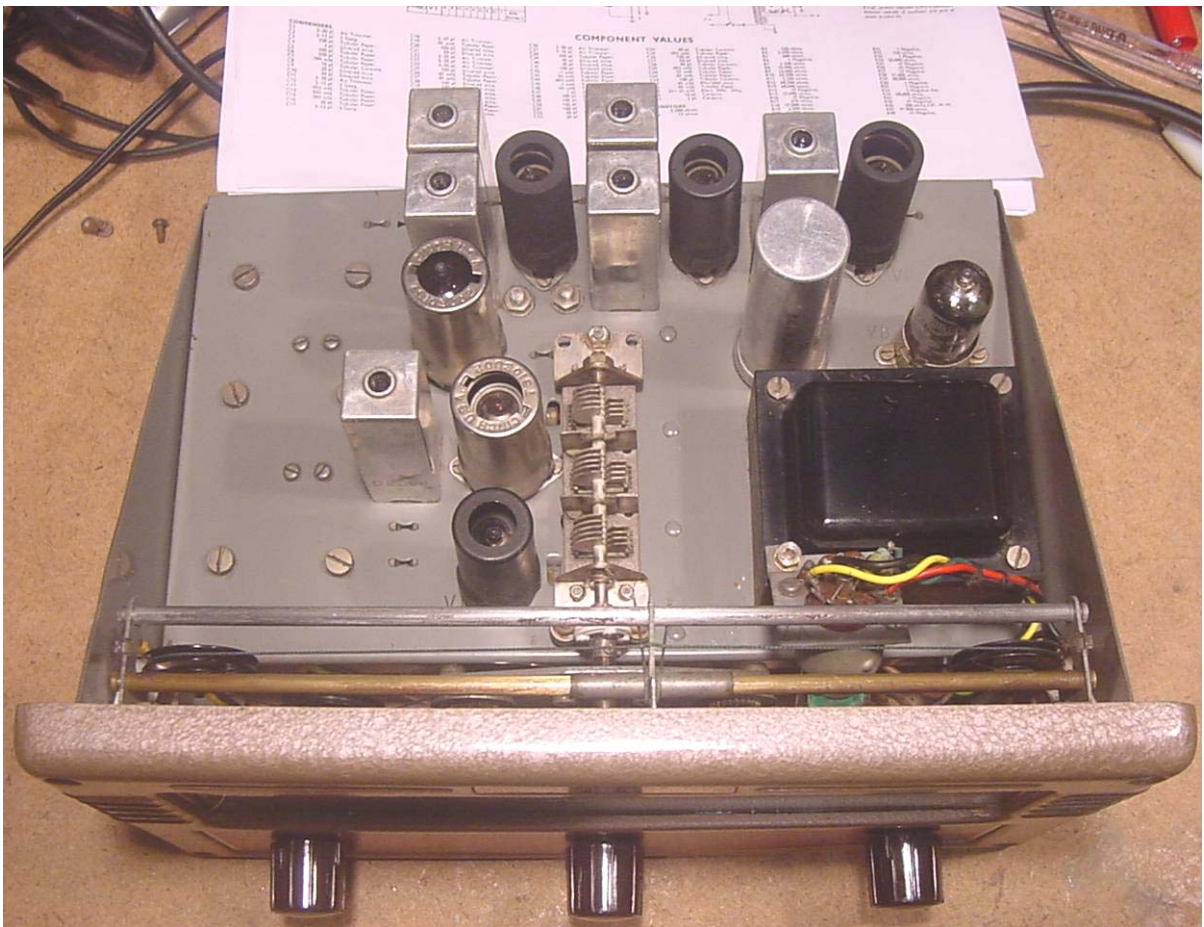

earlier, so I began to fear that there was a fault in the first IF transformer. However, while prodding about around the 12AT7 valve base I noticed that the stiff wire coupling the IF transformer to pin 1 had become detached (circled in photo, right) – this was not noticeable when viewed from most angles, the joint looked intact. A quick dab of solder later the VHF section was also working! I completed checking voltages and the only real discrepancy remaining was the voltage on the anode of the triode section of the EM80 ‘magic-eye’ (39v instead of the indicted 27v). R34 (1mohm) checked out ok, so I decided to leave it alone for now as the indicator was working correctly.



- I left the tuner on ‘soak test’ for a few hours and nothing seemed to be overheating. It stayed working ok during this period, but it seemed very ‘deaf’, particularly on VHF, where the received signals were also somewhat distorted.

### Preliminary Re-Alignment

Given that the voltage checks appeared ok and that the valves all checked out as ‘good’, I decided that the VHF deafness may be due to poor alignment (a ‘mad twiddler’ had obviously been at the cores as there were tell-tale signs of minor scratch marks around the IF can openings and one of the cores was partly out of the top of the can).

The S.820 manual contains the alignment procedure – pretty standard, however, the slightly different method I used is as follows, which prevents AGC action interfering with alignment of the AM section:

#### AM Section

- Switch on the tuner and the signal generator for an hour or so to thoroughly warm up. Set the signal generator to 30% modulation and the attenuator backed off about half way;
- Connect the output meter across the AF output connector – this allows audio monitoring when needed/wanted while also using the output meter;
- Short out the AM local oscillator (LO) grid to ground, where C32 connects to the bandchange switch, using a short jumper lead to stop the LO working and connect the signal generator output to the



- grid of the mixer valve, V3;
- Short out the AGC line to ground to maximize gain;
- Set the signal generator to 465KHz for the IF alignment. If you notice multiple peaks, select the strongest one (it should be near the nominal IF of 465kHz). Connect the signal generator output to the grid of the frequency changer (pin 1). Peak the cores of T1 and T2. Repeat at least once as some of the adjustments may interfere with each other, gradually backing off the applied signal using the attenuator on the signal generator as needed to provide a reasonable output meter reading;
- Once no further improvement can be attained, remove the shorts from the LO capacitor and AGC line and remove the signal generator lead from the grid of the mixer valve;
- Connect a 330ohm ¼W resistor across the aerial connector (one connection post earthed) and the signal generator to the non-earth end via a 0.0001uf capacitor;
- Follow the alignment procedure for each of the three AM pre-sets as per the manual – I used a VTVM monitoring the AGC line voltage to peak tuning on the desired station;
- One of the LO coil slugs was broken in my set – I slowly coaxed it out of the former (took half an hour) cleaned out the broken parts, this being the upper section where the slot in the slug had been subject to stress, probably as a result of someone forcing it using an incorrectly sized tool, and replaced it the other way around, so the good slot end was facing upwards, placing a little Rocol Kilopoise on the slug.
- Hey presto, the AM section is done. Now for VHF mode.

#### VHF Section

- Switch to VHF;
- Disconnect the earthy end of R27 at the limiter valve grid and insert a 50uA meter in series with the disconnected end and ground. This acts as a tuning indicator for this part of the alignment procedure;
- Follow the 10.7mHz IF, RF and Discriminator alignment as per the manual – I found that this procedure works very well.
- Reconnect R27 to ground.
- Hey presto, the FM section is also done.



#### More Clean-up and Mechanical Work

The chassis as received was rather 'grubby'. I tried my usual rubbing alcohol and lighter fluid solvents to no avail. After some experimentation, I found that a strong washing-up liquid/water solution worked much better to remove whatever was covering the paint. I then used 'Brasso' to polish up the black finish on the power transformer shroud, cleaned-up each valve envelope and applied De-Oxit to the valve pins/sockets. I also repaired the two valve base screen retaining collars by gluing with a carefully-placed small dab of 'JB Weld' – a steel-strengthened epoxy-based glue designed for joining

metal, available in DIY and some hobby shops here in Canada (this was a lot easier than replacing the valve bases).

### 'HiFi' Listening Test

I undertook a listening test with the tuner coupled to my (unfortunately solid state) 'HiFi' system - actually a homebrew dual 100W/channel power amplifier (labeled 'Krank' on the photo, right) constructed in a very large Kingston power supply case way back in 1986, coupled to a separate op-amp preamp scratch-constructed from an article in Practical Wireless at the same time, the amplifier outputs are fed to a pair of speakers constructed from Wilmslow audio kits of similar vintage. My usual tuner is a high-quality solid state stereo Akai unit (photo, left), dating from mid-1990's (picked up in a Salvation Army 'Thrift' store for a bargain price of just \$15).



Compared with the Akai, the Eddystone on FM sounded very 'crisp' with a full, powerful base and lots of presence on the vocals, to the point of being very slightly 'edgy' on some programming, suggesting that the discriminator de-emphasis characteristics may not be exactly right. Noise levels (hum and hiss) were very low on strong signals and the quality is quite acceptable and provides very easy-listening (I double-checked the discriminator adjustment and it was found to be



ok). The tuner is very sensitive, with full quieting on just a foot or so of wire stuck in its VHF antenna socket. Also, given that there is no AFC circuitry present, the Eddystone is remarkably stable and sits firmly on the selected frequency after the first half hour or so of warming-up – a testament to the solid construction techniques used, component selection



and design of the oscillator circuit. The AM reception is also good, though obviously the sound quality is not in the same league as on FM.

### Conclusion

The Eddystone S.820 is quite a remarkable performer considering the limitations of its relatively simple circuitry. It relies mainly on quality components and strong mechanical construction to achieve adequate stability on VHF rather than innovative design. Its really outstanding features are the lovely smooth tuning controls – an Eddystone hallmark of course, and its very good sensitivity on VHF (mine closes the ‘magic-eye’ on a foot of wire in my basement workshop on several stations) – being able to operate well in marginal signal areas was a definite advantage in the early days of FM broadcasting and a therefore a good marketing feature. A limitation of the tuner in today’s FM band is that it only tunes to 101.5 MHz if the dial calibration is used when aligning.



It’s a very cute little set though and well worth the effort to acquire one and restore it to fully working condition. I will probably be using my S.820 mostly in my workshop to provide background music rather than connected to my ‘HiFi’ system as a ‘retro component’, though I am considering making a case for the set along the lines of one from an S.870 so the chassis does not become a dust-collector... that will be the subject of another article though. I would also note that one of my friends owns a high-quality valve-based HiFi amplifier set-up and he is interested in trying out the S.820 also – it will be interesting to see what the sound is like through such a system.

73’s

© Gerry O’Hara, G8GUH ([gerryohara@telus.net](mailto:gerryohara@telus.net)), Vancouver, BC, Canada, October, 2007

### Some Useful References

- Radio and Television Receiver Circuitry and Operation, Ghirardi and Johnson, 1951
- Radio and Television Receiver Troubleshooting and Repair, Ghirardi and Johnson, 1952
- Electronics One-Seven, H Mileaf, 1967
- Radio servicing: Theory and Practice, A Marcus, 1948
- Radio Receiver Servicing, JT Frye, 1955
- Elements of Radio Servicing, Marcus and Levy, 2<sup>nd</sup> Ed. 1955, (the first edition of this book can be downloaded in pdf format from [http://www.archive.org/details/Elements\\_Of\\_Radio\\_Servicing](http://www.archive.org/details/Elements_Of_Radio_Servicing))
- Various documents downloaded from the EUG website, including:
  - The Ultimate Quick Reference Guide (QRG), 2<sup>nd</sup> Ed., 2005, Graham Wormald, G3GGL
  - S.820 Manual
- Websites (as well as the EUG site <http://www.eddystoneusergroup.org.uk/>):
  - <http://home.mira.net/~kiewavly/Leak.html>
  - <http://www.blackwidowaudio.com/index.htm>
  - <http://www.collectableaudio.com/page11.html>
  - <http://www.arar93.dsl.pipex.com/mds975/Content/ukradio2.html>



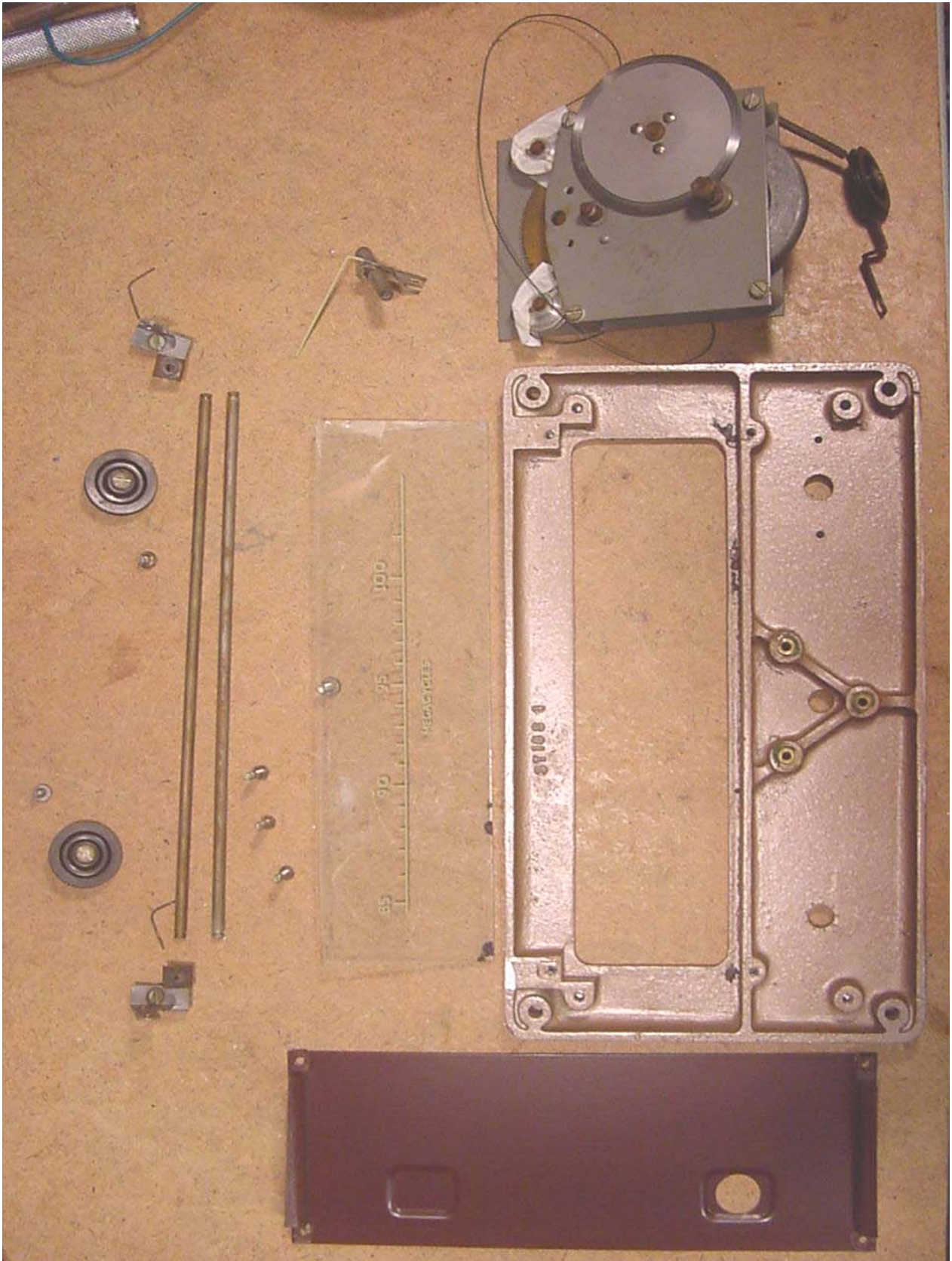

Above: The completely disassembled front panel and No. 898 drive parts (I did not take the gearbox apart as it was working fine and only needed the removal of gummy grease and re-lubrication. Note the lack of any S.820 identification on the rear scale plate (bottom of photo))



Above: Notice the slightly warped front panel casting – discussed in the text. Below left: yes, I finally invested in some BA nut runners. Below right: The tuning capacitor gang after being ‘Silvo’d’. Note the glass bead forming the rear shaft bearing (bottom of photo)

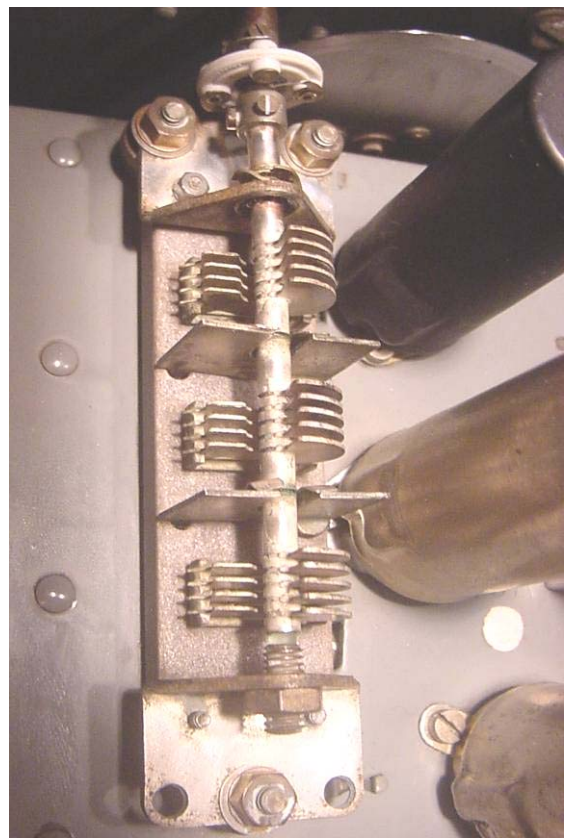

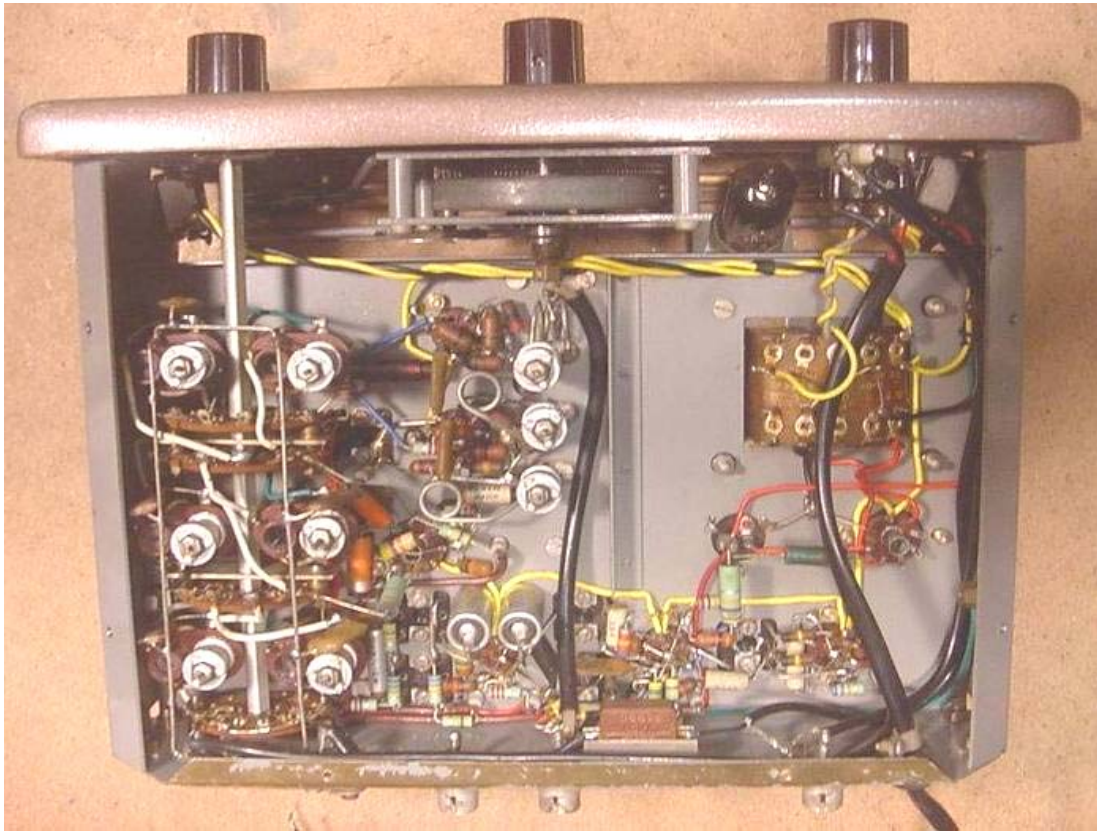

Above: Under-chassis view before safety improvements to the power supply.  
Below: after fitting a fuse and replacing the power cord with a three-core cable

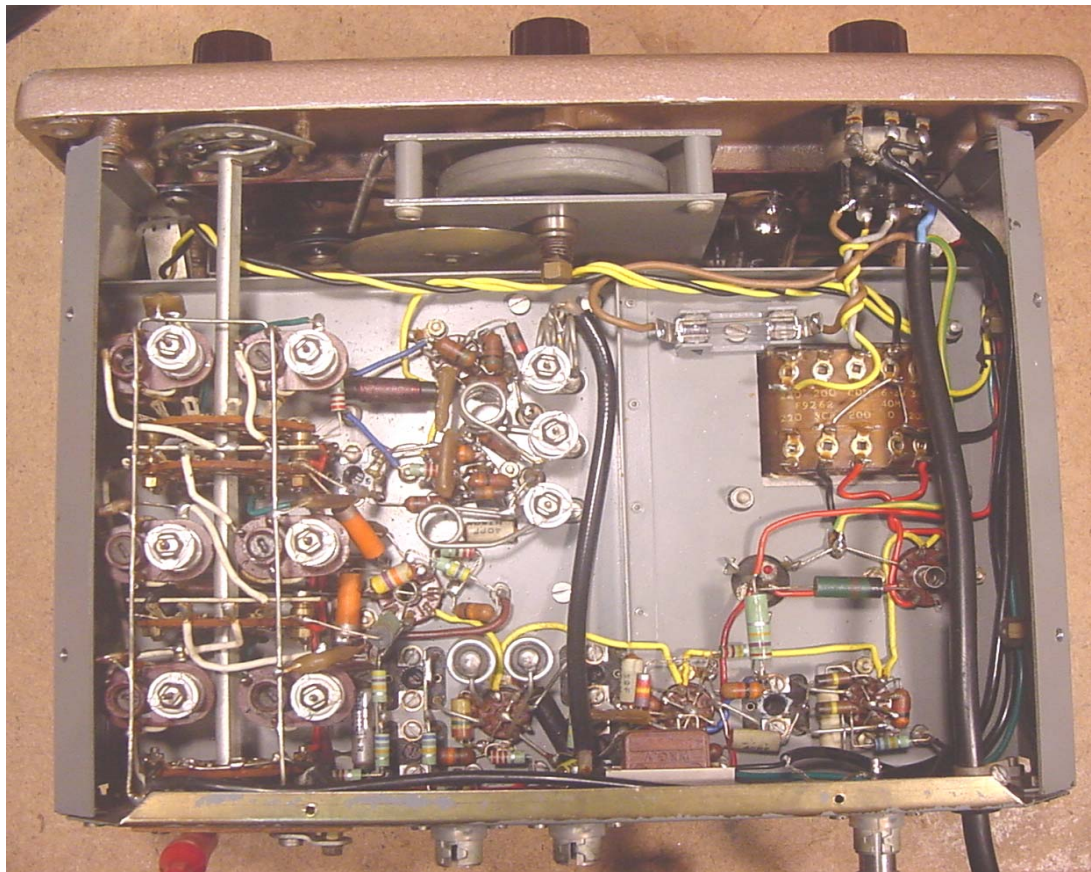



Above: Under-chassis view with the cover plate in place. Below, rear chassis view – note the ‘one-size fits all’ connectors (all horrid little Belling-Lees) – ‘wot, no phonos?’

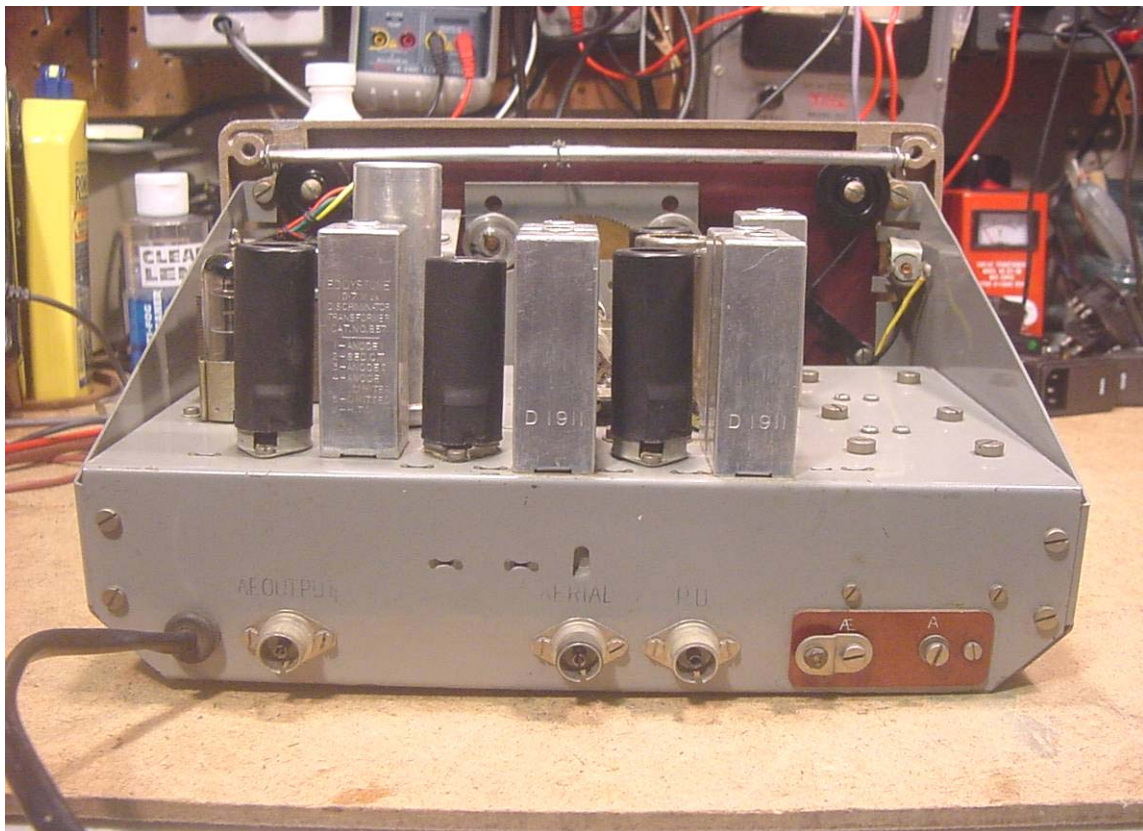

# The EDDYSTONE '820'

## V.H.F (F.M)

### Sound Receiving Unit

*Clarity*

*Fidelity*

*Range*



Designed for reception of VHF/FM transmissions; also for one pre-set long wave station and two pre-set medium wave stations. The "820" is of advanced design, precision built using first-class materials. It is a product of Stratton & Co. Ltd., who enjoy a World-wide reputation for Communication equipment of the highest standard.

#### OPERATION

Continuous tuning is available over Band II and the horizontal dial is clearly marked in frequency. It is a simple matter to tune straight on to the desired station, final correct adjustment being shown by maximum expansion of the glow in the fluorescent tuning indicator. Your dealer will set up the pre-set medium and long wave positions to frequencies you specify, as this operation should preferably be carried out with proper test equipment, although on occasions adjustments may be made on the signals from the desired station, if these are fairly strong.

Thereafter, it is only necessary to turn the switch to one or other of the indicated positions, and adjust the volume to suit.

#### GUARANTEE

The Eddystone "820" Receiving Unit is guaranteed against faulty workmanship or components (excluding valves) for 12 months from date of purchase. The valves are covered by the normal guarantee issued by the British Radio Valve Manufacturers' Association.

List Price £38 : 0 : 0 (INCLUDING PURCHASE TAX £9 : 10 : 0)

22 —

9-18-0



Manufacturers :

**STRATTON & CO. LTD.**  
BIRMINGHAM 31 :: ENGLAND

Telephone: PRIORY 2231

Cables: STRATNOID, BIRMINGHAM



MANUFACTURERS OF SPECIALISED SHORT WAVE RADIO EQUIPMENT SINCE 1925

SUPPLIED BY

WEBB'S  
14, SOHO STREET,  
LONDON, W.1.

Printed in England

# THE EDDYSTONE "820" RECEIVING UNIT

The advent of sound broadcasting on VHF channels and using frequency modulation opens up a new era of radio reception, free from interference and with a clarity not generally possible on lower frequencies. But to make the most of the new system, it is necessary to use a receiving unit specially designed and built to give the best possible results.

Whilst, as the B.B.C. emphasise, the main virtue of the new system is freedom from annoying whistles and odd noises, the very fact that interference is not present allows the receiver to be designed so that it accepts the whole wide band of frequencies included in the transmitted signal and a greatly improved tonal quality results.

It follows that what a listener actually hears is largely dependent on the receiving equipment and, particularly with connoisseurs interested in concert and similar performances, attention should be focussed on a unit with a guaranteed figure of merit.

Such is the Eddystone "820" Broadcast Receiving Unit. For those technically minded, the specification is given later, in the confident knowledge that the figures will immediately convey the excellence of the technical design. As in all Eddystone receivers, the "820" Unit is of robust construction and embodies workmanship of the highest grade. To those interested in results rather than the ways and means by which they are obtained, you can purchase in the full confidence that products of the Eddystone factory do all that is claimed for them, without any exaggerations being made.

## MEDIUM & LONG WAVE FACILITIES

Although Home, Light and Third programmes are available on VHF channels, there may be occasions when other stations are wanted—for instance, another Home Region or a European station. Also, in many areas, it may be some time before VHF

stations are operating and reception of medium and long wave stations is necessary. Hence the inclusion in the "820" Unit of two pre-set medium wave positions and one pre-set long wave position.

## SPECIFICATION

### FREQUENCY COVERAGE.

Complete continuous tuning over Band II 87.5 to 100 Mc/s.

One spot frequency between 1550 and 960 kc/s. (MW1).

One spot frequency between 960 and 610 kc/s. (MW2).

One spot frequency between 250 and 150 kc/s. (LW).

### CIRCUIT AND VALVES VHF/FM.

|    |       |                            |
|----|-------|----------------------------|
| V1 | 6AM6  | RF Amplifier.              |
| V2 | 12AT7 | Frequency Changer.         |
| V3 | ECH42 | 10.7 Mc/s. I.F. Amplifier. |
| V4 | 6AM6  | 10.7 Mc/s. I.F. Amplifier. |
| V5 | 6AM6  | Limiter.                   |
| V6 | 6AL5  | Discriminator.             |
| V7 | EM80  | Tuning Indicator.          |
| V8 | EZ41  | Full wave Rectifier.       |

On medium and long waves V3 becomes a frequency changer, V4 an I.F. amplifier on 465 kc/s., whilst a germanium diode is used as demodulator.

### TUNING DRIVE AND SCALE.

The scale is printed clearly on a glass dial which is edge illuminated. The tuning drive is gear driven with spring-loaded gears to prevent backlash and the tuning knob is flywheel loaded for smooth control.

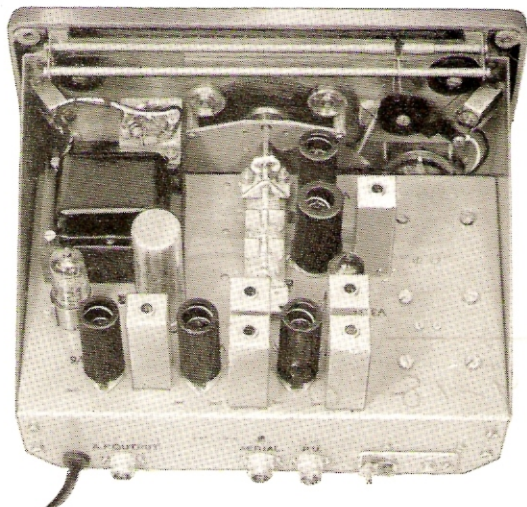

Rear view of the "820" Unit, illustrating the clean engineering lines.

### PERFORMANCE VHF/FM.

An input of 25 microvolts gives 1 volt at the limiter grid, and ensures full limiting action. Selectivity figures:— 6 db down 100 kc/s. off resonance and 25 db down 200 kc/s. off. I.F. break-through greater than 70 db down at 10.7 Mc/s. Image attenuation 35 db. Audio output 0.5 volts (approx) for 30% modulation (= 22.5 kc/s. deviation).

### PERFORMANCE MW AND LW.

Sensitivity is adequate for good results with a comparatively small aerial. Image ratio greater than 35 db. Selectivity 25 db down 10 kc/s. off resonance (465 kc/s.). Audio output 0.2 volt approx., 30% modulation, 400 cycles, 50 microvolts input.

**Output** is at high impedance to match into grid circuit of average amplifier.

**Input Impedance.** Approximately 75 ohms on Band II, and suitable for a random length of aerial on other frequencies.

**Power Supply.** Built-in power unit operating from A.C. mains 200/240 volts, 40/100 cycles.

### CONTROLS.

Five position switch to select:— pick-up; medium wave one; medium wave two; long wave; F.M.

### CONSTRUCTION AND FINISH.

The front panel is a diecasting, finished polychromatic hammer enamel. The brass chassis is fitted with a protective cover, both finished radio grey.

### DIMENSIONS AND WEIGHT.

|                  |                    |
|------------------|--------------------|
| Panel Height ... | 6½ inches.         |
| Panel Width ...  | 11 inches.         |
| Depth ...        | 10 inches overall. |
| Weight ...       | 11½ lbs.           |

## EASE OF INSTALLATION

Installation of the Eddystone "820" Unit presents no problems. It has its own power supply, so avoiding any need to draw power from other equipment. A connection to the mains is required and usually this will be common with the amplifier or receiver used with the "820." One socket takes the feeder coming from the special Band II aerial, about which your dealer will give advice. Another accepts the plug on a length of coaxial cable which it is recommended be used for interconnecting purposes. The audio output from the "820" is ample, either for feeding into a high fidelity amplifier or into the pick-up terminals of a broadcast receiver.

When Medium or Longwave reception is required, an ordinary aerial and earth should be connected to the appropriate terminals.



Manufacturers :  
**STRATTON & CO. LTD.**  
BIRMINGHAM 31 :: ENGLAND  
Telephone : PRIORY 2231      Cables : STRATNOID, BIRMINGHAM



MANUFACTURERS OF SPECIALISED SHORT  
WAVE RADIO EQUIPMENT SINCE 1925

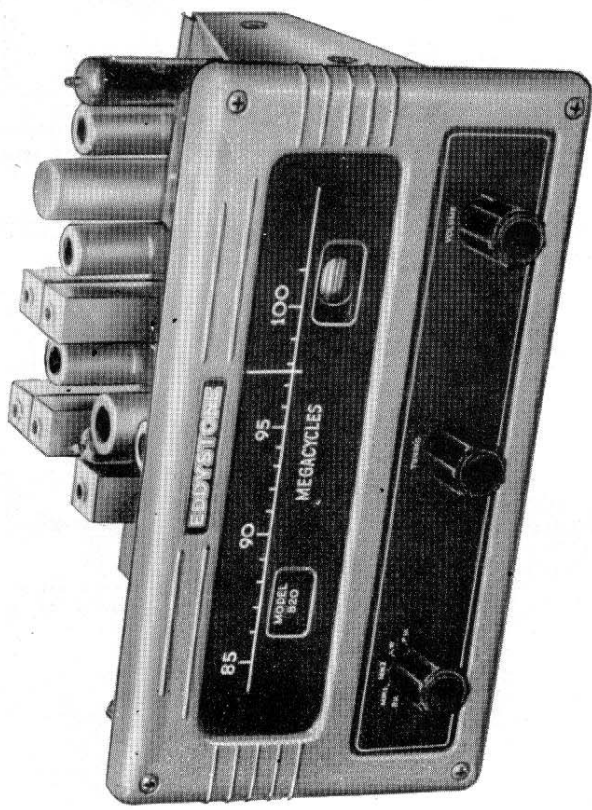

# EDDYSTONE "820" RECEIVING UNIT

## Instruction Manual

The Eddystone "820" Unit is designed for reception of broadcast transmissions in the very high frequency band 87.5 Mc/s. to 100 Mc/s. and facilities are also provided for reception of one spot frequency in the long wave range (150 to 250 kc/s.) and two spot frequencies on medium waves (600 to 1550 kc/s.).

The audio output is at a level adequate for feeding into an amplifier or pick-up terminals and the unit is provided with its own A.C. operated power supply, so avoiding any necessity of finding this externally.

# INSTALLATION DETAILS

Tappings are provided on the mains transformer for 200, 220 and 240 volt supplies, and a check should be made that the tapping in use is the one most closely corresponding to the local supply voltage.

From the audio output socket on the unit, a screened lead is taken to the amplifier, keeping this lead as short as possible to minimize attenuation of the higher frequencies and pick-up of hum. The method of attaching the cable to the plug provided is illustrated below.

The feeder cable from the Band II aerial is plugged into the appropriate socket and the aerial for medium and long wave reception connected to the aerial terminal. It is desirable also to use an earth, connected to the terminal provided.

There is one other socket in the unit, marked "P.U." To this can be taken a lead from the pick-up used with record-playing equipment and then, simply by rotation of the control knob and without disturbing any connections, facilities are immediately available for (a) reception on V.H.F. channels. (b) reception on medium or long wave channels and (c) record reproduction.

The sensitivity of the unit, (on medium and long waves) is such that good reception of stations at no great distance is feasible with only a few yards of insulated wire as an aerial, but for the best results, and where Continental stations are wanted, it is advisable to erect a good outdoor aerial.

In areas of high signal strength, it may be necessary to fit an attenuator between the aerial feeder and the coaxial input socket, to prevent overloading.

## OPERATION

The Unit is switched on by rotating the volume control (right hand knob) in a clockwise direction. The dial will be illuminated immediately and after a short interval the Magic Eye tuning indicator will glow.

It takes a little longer for a receiver of this type to settle down, compared to one operating on medium frequencies and it is therefore advisable to switch on some ten to fifteen minutes beforehand, to allow a stable operating temperature to be reached.

For the Band II V.H.F. stations, the control knob (on the left) is moved to the "F.M." position and the three local stations will then be found on their allotted frequencies (Note—the Third Programme is not usually available during the day). The correct tuning point is when the glow in the Magic Eye indicator expands to the maximum degree. It will also be noticed that when a V.H.F. station is correctly tuned in, the background noise will disappear almost completely and, with the 820 Unit, this effect will occur even with comparatively weak signals.

The pre-set M.W. and L.W. positions will have been set up beforehand to the frequencies of the local stations (Droitwich on the L.W. band) and it is only necessary to move the control knob to the appropriate positions to receive these stations.

Actually, in switch position M.W.1., any frequency between 960 and 1550 kc/s. can be set up, and similarly between 610 and 960 kc/s. in position M.W.2. It is generally desirable to use proper test equipment for setting up on a frequency different to the one already in use and the Dealer should be consulted on this point when necessary.

## PHYSICAL INSTALLATION

The foregoing instructions relate to the use of the 820 Unit, as a separate entity. In many cases, it will be desired to include the Unit as part of an installation comprising amplifier, record reproducer and loudspeaker, and the frontal area of the "820" has been kept small with this in mind.

An aperture 10½" wide by 57" high is required in the cabinet and the necessary fixing screws and rear plates are supplied with the Unit. These plates should be fixed crosswise to clamp on to the woodwork. Care should be taken fitting the Unit in place to ensure proper clearance for the flywheel at the bottom, and the pointer carrier guide at the top.

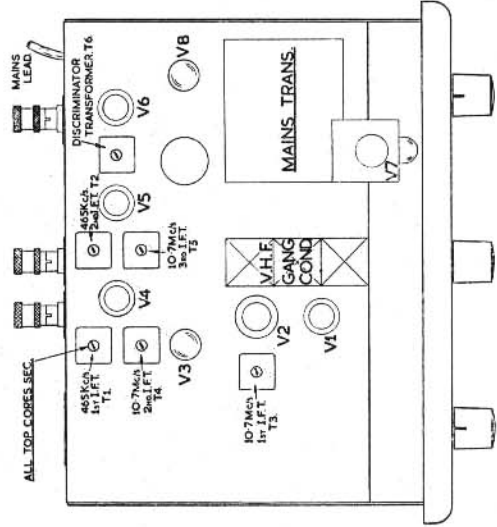

PLAN VIEW OF "820" IN OUTLINE.

## METHOD OF ATTACHING CABLE

- Trim Feeder by removing 1" Outer Cover, 2" of Braid and 1" of Insulation.
- Slide Clamping Nut and Collet onto Feeder and apply the Insulation sharply for soldering. Solder and Trim.
- Slide Collet up to played ends of Braid and crimp Braid flush with Plug Housing, only the inner wire Plug to that Collet enters it. Screw Nut on firmly to Crimp Feeder. The Plug Nut must be firm.
- In the case of Feeder larger than 1" dia. over Cover, the Collet Clamp goes over the Braid only.

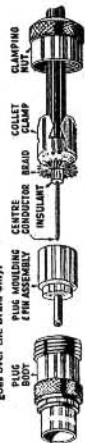

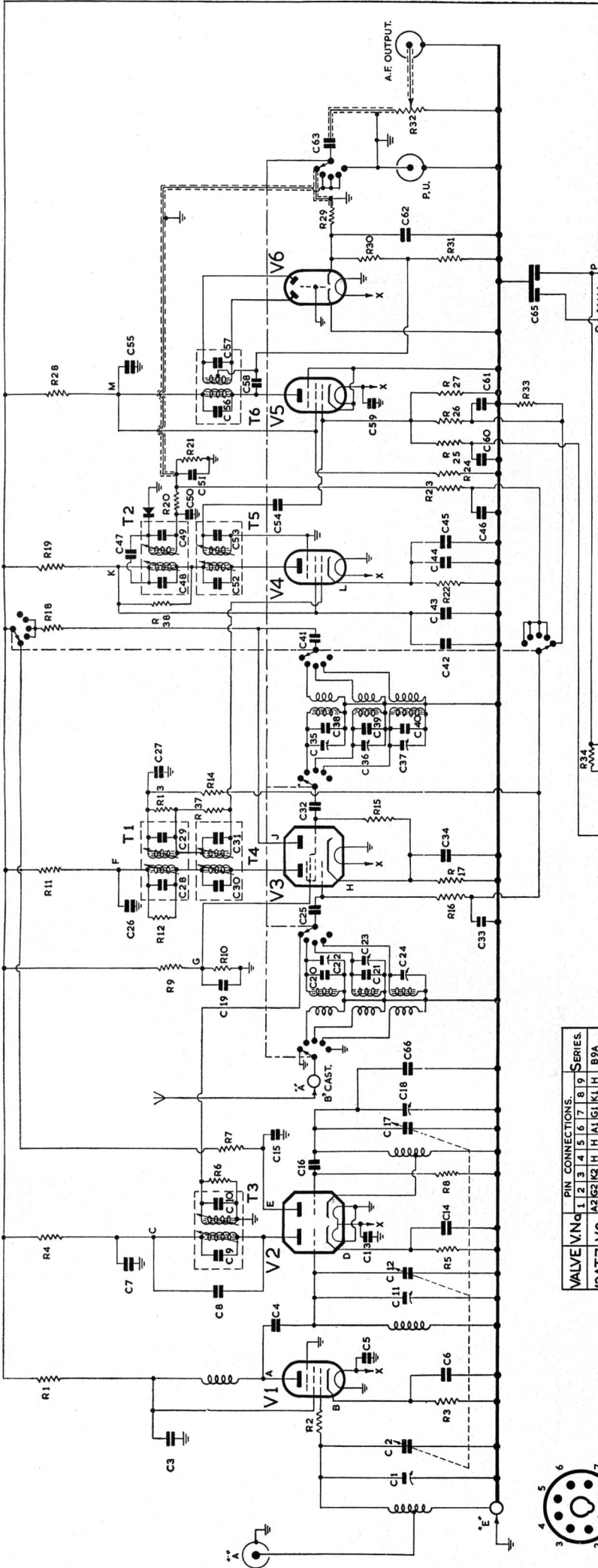

A 3 pf. ceramic capacitor (C67) is connected between cathode of oscillator and grid of mixer in valve V2.

### COMPONENT VALUES

- CONDENSERS.**
- C1 3-30 pf.
  - C2 2-15 pf.
  - C3 500 pf.
  - C4 3 pf.
  - C5 500 pf.
  - C6 500 pf.
  - C7 .003 mfd.
  - C8 10 pf.
  - C9 20 pf.
  - C10 20 pf.
  - C11 3-30 pf.
  - C12 2-15 pf.
  - C13 .003 mfd.
  - C14 .003 mfd.
  - C15 .003 mfd.
  - C16 40 pf.
  - C17 2-15 pf.
  - C18 3-30 pf.
  - C19 Air Trimmer.
  - C20 3 Gang.
  - C21 Tubular Paper.
  - C22 Tubular mica.
  - C23 3 pf.
  - C24 Tubular Paper.
  - C25 Tubular Paper.
  - C26 500 pf.
  - C27 500 pf.
  - C28 10 pf.
  - C29 20 pf.
  - C30 20 pf.
  - C31 3-30 pf.
  - C32 3 Gang.
  - C33 20 pf.
  - C34 Tubular Paper.
  - C35 Tubular Paper.
  - C36 3-30 pf.
  - C37 Air Trimmer.
  - C38 Tubular Paper.
  - C39 200 pf.
  - C40 40 pf.
  - C41 40 pf.
  - C42 100 pf.
  - C43 .01 mfd.
  - C44 Tubular Paper.
  - C45 .003 mfd.
  - C46 .01 mfd.
  - C47 100 pf.
  - C48 100 pf.
  - C49 100 pf.
  - C50 100 pf.
  - C51 100 pf.
  - C52 20 pf.
  - C53 20 pf.
  - C54 Air Trimmer.
  - C55 Air Trimmer.
  - C56 Tubular mica.
  - C57 100 pf.
  - C58 50 pf.
  - C59 40 pf.
  - C60 40 pf.
  - C61 100 mfd.
  - C62 .01 mfd.
  - C63 100 pf.
  - C64 32-132 mfd.
  - C65 10 pf.
  - C66 3 pf.
  - C67 3 pf.
- RESISTORS.**
- R1 2,200 ohms.
  - R2 12 ohms.
  - R3 150 ohms.
  - R4 2,200 ohms.
  - R5 680 ohms.
  - R6 50 pf.
  - R7 2,200 ohms.
  - R8 10,000 ohms.
  - R9 33,000 ohms.
  - R10 27,000 ohms.
  - R11 2,200 ohms.
  - R12 2,200 ohms.
  - R13 2,200 ohms.
  - R14 68,000 ohms.
  - R15 1 Megohm.
  - R16 47,000 ohms.
  - R17 270 ohms.
  - R18 27,000 ohms.
  - R19 2,200 ohms.
  - R20 22,000 ohms.
  - R21 22,000 ohms.
  - R22 1 Megohm.
  - R23 150 ohms.
  - R24 1 Megohm.
  - R25 22,000 ohms.
  - R26 .47 Megohm.
  - R27 .27 Megohm.
  - R28 27,000 ohms.
  - R29 66,000 ohms.
  - R30 1 Megohm.
  - R31 1 Megohm.
  - R32 .5 Megohm Pot.
  - R33 68,000 ohms.
  - R34 1 Megohm.
  - R35 .47 Megohm.
  - R36 500 ohms.
  - R37 1W. W.W.
  - R38 47,000 ohms.

| VALVE | V1   | V2   | V3   | V4    | V5   | V6 | V7 |
|-------|------|------|------|-------|------|----|----|
| 12AT7 | 6AM6 | 6AL5 | EZ41 | ECH42 | EMBO | V6 | V7 |
| 1     | 1    | 1    | 1    | 1     | 1    | 1  | 1  |
| 2     | 2    | 2    | 2    | 2     | 2    | 2  | 2  |
| 3     | 3    | 3    | 3    | 3     | 3    | 3  | 3  |
| 4     | 4    | 4    | 4    | 4     | 4    | 4  | 4  |
| 5     | 5    | 5    | 5    | 5     | 5    | 5  | 5  |
| 6     | 6    | 6    | 6    | 6     | 6    | 6  | 6  |
| 7     | 7    | 7    | 7    | 7     | 7    | 7  | 7  |
| 8     | 8    | 8    | 8    | 8     | 8    | 8  | 8  |
| 9     | 9    | 9    | 9    | 9     | 9    | 9  | 9  |
| 10    | 10   | 10   | 10   | 10    | 10   | 10 | 10 |
| 11    | 11   | 11   | 11   | 11    | 11   | 11 | 11 |
| 12    | 12   | 12   | 12   | 12    | 12   | 12 | 12 |
| 13    | 13   | 13   | 13   | 13    | 13   | 13 | 13 |
| 14    | 14   | 14   | 14   | 14    | 14   | 14 | 14 |
| 15    | 15   | 15   | 15   | 15    | 15   | 15 | 15 |
| 16    | 16   | 16   | 16   | 16    | 16   | 16 | 16 |
| 17    | 17   | 17   | 17   | 17    | 17   | 17 | 17 |
| 18    | 18   | 18   | 18   | 18    | 18   | 18 | 18 |
| 19    | 19   | 19   | 19   | 19    | 19   | 19 | 19 |
| 20    | 20   | 20   | 20   | 20    | 20   | 20 | 20 |
| 21    | 21   | 21   | 21   | 21    | 21   | 21 | 21 |
| 22    | 22   | 22   | 22   | 22    | 22   | 22 | 22 |
| 23    | 23   | 23   | 23   | 23    | 23   | 23 | 23 |
| 24    | 24   | 24   | 24   | 24    | 24   | 24 | 24 |
| 25    | 25   | 25   | 25   | 25    | 25   | 25 | 25 |
| 26    | 26   | 26   | 26   | 26    | 26   | 26 | 26 |
| 27    | 27   | 27   | 27   | 27    | 27   | 27 | 27 |
| 28    | 28   | 28   | 28   | 28    | 28   | 28 | 28 |
| 29    | 29   | 29   | 29   | 29    | 29   | 29 | 29 |
| 30    | 30   | 30   | 30   | 30    | 30   | 30 | 30 |
| 31    | 31   | 31   | 31   | 31    | 31   | 31 | 31 |
| 32    | 32   | 32   | 32   | 32    | 32   | 32 | 32 |
| 33    | 33   | 33   | 33   | 33    | 33   | 33 | 33 |
| 34    | 34   | 34   | 34   | 34    | 34   | 34 | 34 |
| 35    | 35   | 35   | 35   | 35    | 35   | 35 | 35 |
| 36    | 36   | 36   | 36   | 36    | 36   | 36 | 36 |
| 37    | 37   | 37   | 37   | 37    | 37   | 37 | 37 |
| 38    | 38   | 38   | 38   | 38    | 38   | 38 | 38 |
| 39    | 39   | 39   | 39   | 39    | 39   | 39 | 39 |
| 40    | 40   | 40   | 40   | 40    | 40   | 40 | 40 |
| 41    | 41   | 41   | 41   | 41    | 41   | 41 | 41 |
| 42    | 42   | 42   | 42   | 42    | 42   | 42 | 42 |
| 43    | 43   | 43   | 43   | 43    | 43   | 43 | 43 |
| 44    | 44   | 44   | 44   | 44    | 44   | 44 | 44 |
| 45    | 45   | 45   | 45   | 45    | 45   | 45 | 45 |
| 46    | 46   | 46   | 46   | 46    | 46   | 46 | 46 |
| 47    | 47   | 47   | 47   | 47    | 47   | 47 | 47 |
| 48    | 48   | 48   | 48   | 48    | 48   | 48 | 48 |
| 49    | 49   | 49   | 49   | 49    | 49   | 49 | 49 |
| 50    | 50   | 50   | 50   | 50    | 50   | 50 | 50 |
| 51    | 51   | 51   | 51   | 51    | 51   | 51 | 51 |
| 52    | 52   | 52   | 52   | 52    | 52   | 52 | 52 |
| 53    | 53   | 53   | 53   | 53    | 53   | 53 | 53 |



B7G SERIES.



B8A SERIES.

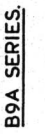

B9A SERIES.

# SERVICING INSTRUCTIONS

## ALIGNMENT.

For complete alignment, the following equipment is required:—

Signal Generator(s): 150 kc/s. to 1,600 kc/s. (with A.M.)  
10 Mc/s. to 110 Mc/s. (preferably with F.M.)

Standard Output Meter

0—50 Microammeter.

Trimming tools for coil cores and Phillips-type concentric trimmers.

### 10.7 Mc/s. (F.M.) I.F. Channels.

The earthy end of R27 — the 270,000 ohm resistor at the limiter grid(V6) should be unsoldered and the 50 microammeter placed in series with the end of the resistor (neg. terminal of meter) and chassis (positive terminal). The output from the signal generator is fed direct to the grid of V4, and with the generator set to 10.7 Mc/s., the output is increased until a deflection is observed on the microammeter. The cores — primary and secondary — of the third 10.7 Mc/s. I.F. transformer (T5) are adjusted for maximum output. A sensitivity of approximately 15 millivolts for 4 microamps deflection should be obtained.

Next, the generator lead is transferred to the grid of the ECH42 valve (V3) and the 10.7 Mc/s. transformer (T4) in its anode circuit adjusted for maximum deflection of the microammeter. At this point the sensitivity should approximate 700 microvolts for 4 microamps deflection. The generator input is then transferred to the grid (pin 7) of the 12AT7 valve (V2) and the cores of the I.F. transformer T3 trimmed for maximum output.

This completes alignment of the 10.7 Mc/s. circuits. If an accurate check is desired on the I.F. sensitivity, it is necessary to unsolder the wire connected to pin 7 of the 12AT7 and apply the test signal at this point. The oscillator should also be prevented from functioning by temporarily placing a short circuit across the gang condenser section. The sensitivity obtained should be approximately 50 microvolts for a deflection of 4 microamperes.

### Alignment of R.F. Stage.

The pointer on the "820" Unit is set to 100 Mc/s., the generator output fed into the aerial feeder socket, and trimmer C.15 adjusted for maximum deflection of the microammeter. The same procedure is carried out at the other end of the scale—87.5 Mc/s.—and if appreciable falling off in output occurs, a slight adjustment should be made to the inductance, repeating the process until good tracking is obtained. With the generator frequency set to 95 Mc/s., C.1. and C.11. are trimmed for maximum deflection.

### Discriminator Alignment.

The Signal Generator is set to 10.7 Mc/s., unmodulated, output at maximum (1 volt) and the output lead connected to the grid of the limiter valve (V5).

A centre zero 50—50 microammeter is placed across the output of the discriminator valve (V6) with a 100,000 ohm resistor in series — that is, from that cathode above earth, through meter and resistor, to chassis. If the discriminator stage is in proper alignment at 10.7 Mc/s., the meter will read zero and a check should be made by varying the frequency of the applied signal each side of 10.7 Mc/s. For equal frequency variations, the microammeter should give equal deflections each side of zero. If they are unequal, adjustment of the primary (lower) core in the discriminator transformer will bring about a balance.

In the unlikely event of complete re-alignment of the discriminator stage being required, the secondary (upper) core is set so that the top of the core is flush with the top of the discriminator transformer can. Then the lower primary core is adjusted for maximum deflection in the microammeter, after which the upper secondary core is adjusted until the meter reads zero. The balance should be checked as before by varying the applied frequency and any unbalance corrected by further adjustment of the primary core.

The peak deflection obtained should be of the order of 20 microamperes.

### Alignment of 465 kc/s. I.F. Stages.

The generator output lead is clipped to the grid of

valve V.4, the frequency set to 465 kc/s., and the 465 kc/s. I.F. transformer (T2) in the anode circuit adjusted for maximum audio output on the output meter. The generator signal is then transferred to the grid of the ECH 42 (V3) and transformer T1 tuned for maximum response. During this latter operation, the local oscillator should be rendered ineffective by shorting the grid to earth.

The 10.7 Mc/s. circuits should not be disturbed whilst making adjustments to the 465 kc/s. circuits. The "820" control knob should be in the appropriate position for each class of service.

### Long Wave Band.

The signal generator output is applied to the aerial terminal, with the "820" control knob set to "L.W.". The generator frequency should be adjusted as required (e.g. to 200 kc/s. for Droitwich) and the long wave oscillator core rotated until a deflection is observed on the output meter. Fine adjustment is made with the C35 trimmer. Next the core and trimmer associated with the mixer coil are given similar attention until final maximum deflection is obtained.

### Medium Wave Band.

The procedure is the same as for long waves, ensuring the control knob is in the correct position. On the "MW1" position, any frequency between 960 and 1,550 kc/s. can be set up and between 610 and 960 kc/s. on "MW2."

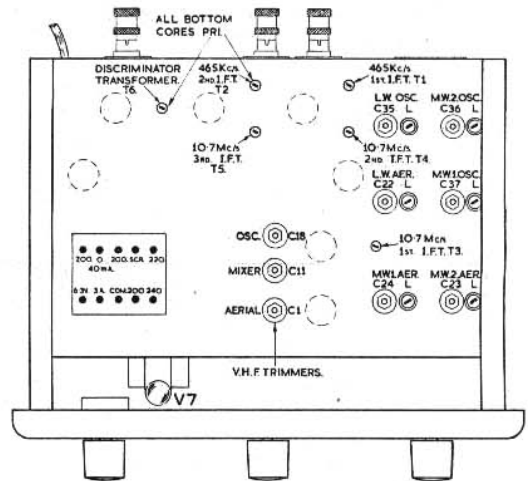

UNDERSIDE VIEW OF "820" IN OUTLINE.

## VOLTAGE VALUES

Voltages are between points indicated and chassis. Set switch to F.M. for points A to E inclusive, and to a Broadcast band for all other points.

Values are given for A.C. input of 240 volts using two types of meter. It is evident that the actual voltage indicated depends on the particular meter employed. A tolerance of  $\pm 5\%$  should be allowed on the values given.

| Point | AVO. 8   | AVO. 40. |
|-------|----------|----------|
| A.    | 170      | 165      |
| B.    | 1.2      | .89      |
| C.    | 168      | 160      |
| D.    | 2.45     | .73      |
| E.    | 168      | 165      |
| F.    | 184      | 178      |
| G.    | 68       | 46       |
| H.    | 1.65     | .83      |
| J.    | 79       | 70       |
| K.    | 170      | 167      |
| L.    | 1.35     | 1.0      |
| M.    | 55       | 42       |
| N.    | 27       | 10       |
| P.    | 187      | 190      |
| Q.    | 200      | 204      |
| R.    | 200 A.C. | 200 A.C. |
| S.    | 200 A.C. | 200 A.C. |

# FM/AM Tuner

## Eddystone Model 820 Embodying a Foster-Seeley Discriminator

WITH so many f.m. tuner units and receivers having almost standardized circuitry it is refreshing to encounter one that is in any way different. The Eddystone Model 820 tuner can perhaps claim this distinction on two counts. In the first case it has a Foster-Seeley discriminator, and secondly it provides the choice of two pre-selected stations in the medium waveband and one in the long. A further distinction is that provision is made also for feeding-in a gramophone output, although there is no actual audio amplification provided.

All three forms of entertainment, f.m. and a.m. broadcasting and records are selected by a single five-position switch.

The tuner has exceptionally high sensitivity and is capable of giving a very satisfactory performance outside the normal service area of a v.h.f. broadcast station.

Following accepted practice the "820" has an r.f. amplifier and all the three associated r.f. circuits, aerial, inter-valve coupling and oscillator, are tuned by a tiny three-gang capacitor designed especially for this unit. It is fitted with a single glass ball-bearing at the rear end of the rotor shaft and this novel innovation has been adopted in order to eliminate loop couplings in the capacitor.

The r.f. valve, (V1), is a 6AM6 r.f. pentode choke-capacitance coupled to the tuned intervalve circuit and followed by a double-triode 12AT7, (V2), functioning as mixer and local oscillator for f.m. reception. The i.f. output from the mixer, which is at

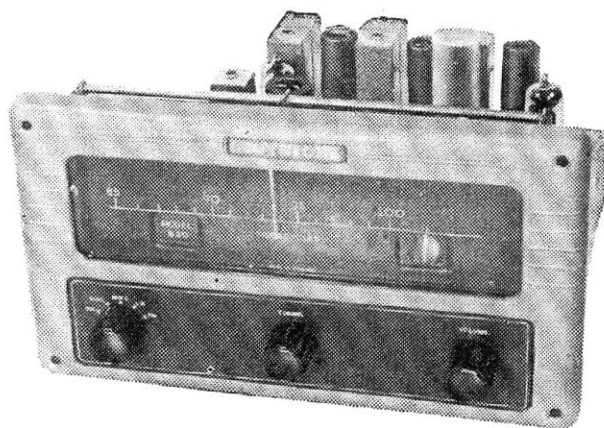

The large scale window with controls below characterizes the Model 820 f.m./a.m. tuner as an Eddystone product.

10.7 Mc/s, is fed *via* the f.m./a.m. switch to the grid of the hexode section in an ECH42, (V3), normal frequency changer. For f.m. reception this section functions as the first i.f. amplifier and its accompanying triode is inoperative.

For a.m. reception the hexode section of the ECH42 becomes the mixer with its triode functioning in the usual way as a local oscillator. For this condition of operation an i.f. of 465 kc/s is employed. I.F. transformers of 10.7-Mc/s and 465 kc/s are connected in series in the anode circuit and automatically select, without switching, the correct i.f. signal according to the mode of operation, e.g., as first i.f. at 10.7 Mc/s or mixer at 465 kc/s. Following the ECH42 is another 6AM6, (V4), functioning as second i.f. on 10.7 Mc/s or first i.f. on 465 kc/s as required.

The 10.7-Mc/s signal passes from V4 to another 6AM6, (V5), which is operated at relatively low anode and screen voltages, and behaves as a limiter. Under working conditions the limiter stage has quite an appreciable amount of grid bias derived from a 0.27-M $\Omega$  grid resistor. This negative d.c. voltage is used also to operate an EM80 magic-eye tuning indicator, (V7), on f.m. and supplies an a.g.c. voltage to the input grids of V3 and V4.

The 10.7-Mc/s discriminator transformer is in the anode circuit of the limiter, (V5), and is followed by a double diode 6AL5, (V6), arranged as a typical Foster-Seeley discriminator, its a.f. output going *via* a de-emphasis network and f.m./a.m. switch to an output volume control.

For a.m. reception the i.f. signal stops short at the anode of the 6AM6, (V4), following the ECH42, (V3), and is there rectified by a crystal diode and the audio output taken, *via* the f.m./a.m. switch to the aforementioned output volume control. The d.c. voltage derived from the

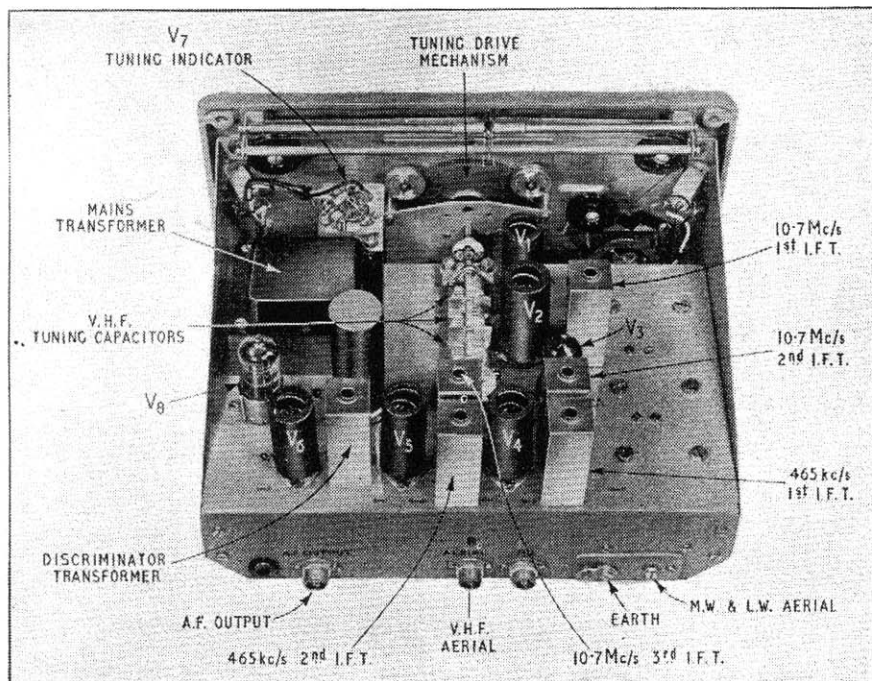

Viewed from the back the positions of the valves, i.f. and mains transformers are clearly seen. Also seen is the tuning mechanism.

crystal current is used for a.g.c. This a.m. grid-bias (or a.g.c. voltage) is not applied to the tuning indicator which is not operative on the pre-set a.m. stations.

The tuner has its own a.c. power supply unit and this comprises a double-wound mains transformer, an EZ41 full-wave h.t. rectifier, (V8), a 500-ohm smoothing resistor and two 32- $\mu$ F smoothing capacitors.

A coaxial socket is provided at the back of the unit for a 70-ohm feeder from the v.h.f. aerial and a screw terminal for a random-length aerial for a.m. reception. Two other coaxial sockets are included at the back; one is the a.f. output, the other is for a gramophone input. There is also an earth terminal.

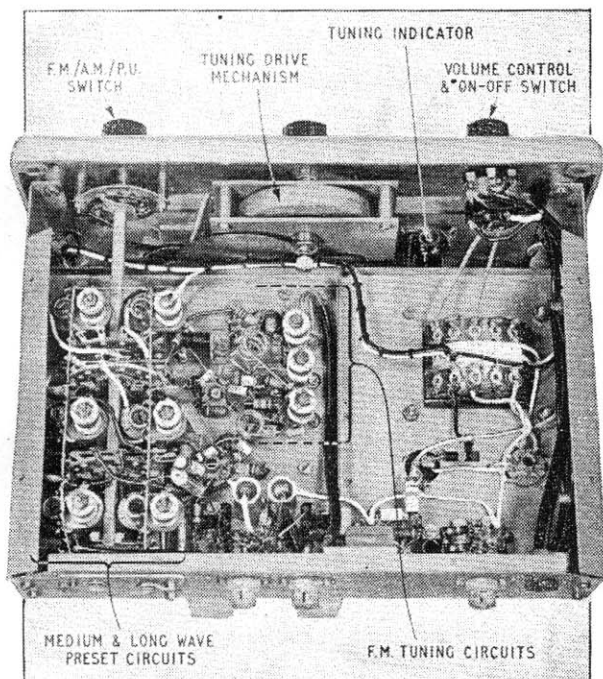

The chassis has a metal base plate which when removed gives access to the tuning circuits, small components and wiring.

In view of the potential high sensitivity of the tuner, tests were carried out at some distance from Wrotham and in a rather poor location from the point of v.h.f. reception on the south coast. As the tuner was designed in Birmingham and reputed to put up a good performance there it was felt this would be a good way of testing its merits.

A further handicap was imposed by using a loft aerial, since no other of the right type was available at the time. It was a single dipole and the direct "line-of-sight" to Wrotham was interrupted by high ground up to 600 to 700ft about 3 miles away. The receiving aerial was just under 200ft above sea level.

The tuner put up a most satisfactory performance, signals being strong enough to give good limiting and entirely suppress the background and all but the most severe interference from passing motor cars.

Aircraft flying in the vicinity of the receiving site are a great nuisance on the v.h.f. bands and while the "820" put up a stout effort in resisting the greater part of the signal flutter they produced it could not cope with the worst kind. So severe can this be at times that it is doubtful if any f.m. receiver would cope with it under all conditions; however, it is possible a better aerial would make a great deal of dif-

ference. Provided the signal is maintained above the limiting level the audio output remains quite steady, despite quite violent "throbbing" of the magic-eye.

Used with a good amplifier and loudspeaker there is a crispness in the reproduction that is rarely possible on other bands owing to the necessity to restrict the receiver's bandwidth in order to keep out interference from stations on nearby wavelengths. Apart from this the most impressive thing about the reception, especially to anyone continuously plagued by whistles, "monkey chatter," and crackles of many kinds, that prevail almost anywhere south of London in the U.K., is the delightfully quiet background.

First impressions may be that not enough de-emphasis is provided, but this will generally prove groundless as greater familiarity is gained with f.m. reception. However, a little tone-correction can generally be applied in the audio amplifier if thought desirable.

The tuning control is delightfully smooth and free of backlash and the "sponginess" sometimes associated with cord drives. Actually the cord drive in the "820" tuner operates the pointer only and the gang capacitor is driven through a combination of spring-loaded gears and friction discs giving an overall reduction of about 76 to 1. A heavy flywheel smooths out any little irregularities in the system.

The tuning scale is just over 6in long and is traversed by a long pendant pointer. It is directly calibrated and covers 85 to 101 Mc/s with points at every megacycle and figures every 5 Mc/s. Viewing is made easy by employing white for figure markings and the pointer and a chocolate-coloured background. The tuning indicator is viewed through a cut-out in the background plate and is enclosed by the scale window. This measures  $8\frac{1}{2} \times 2\frac{3}{8}$ in and takes up the whole of the top half of the front panel. The three controls: AM/FM/PU switch, tuning and volume/on-off, in this order from left to right, are spaced out equidistant below.

The a.m. side of the tuner has been rather ignored so far, but it is well up to the performance of a mixer-i.f.-detector combination. In the MW1 position of the switch any station between 960 and 1,550 kc/s can be set up and in MW2 position the range is 610 to 960 kc/s. The range on long waves is 150 to 250 kc/s.

Since the f.m. side provides the three main programmes, Light, Home and Third, the stations set up on the pre-tuned circuits could with advantage be a regional which sometimes has a programme of local interest, or one's favourite Continental stations.

The tuner is supplied in chassis form as illustrated and measures  $11 \times 6\frac{1}{4} \times 8\frac{1}{4}$ in. The front is a sturdy light-alloy casting and forms a rigid support for the chassis which is braced by side members giving good mechanical rigidity; this rigidity is essential for good frequency stability. High praise can be given to the "820" tuner in this respect as the drift from cold to working temperature is comparatively small for v.h.f. equipment, while the long-term stability is very good indeed. After any initial correction has been made—and this is only necessary if the station is tuned-in immediately the set is switched on—no further attention is needed unless one wants another programme.

The tuner is supplied with all necessary fixing screws, coaxial sockets and trimming tools, and the price is £28 10s, plus £9 10s U.K. purchase tax.

The makers are Stratton and Co., Ltd., Eddystone Works, Alvechurch Road, West Heath, Birmingham, 31.

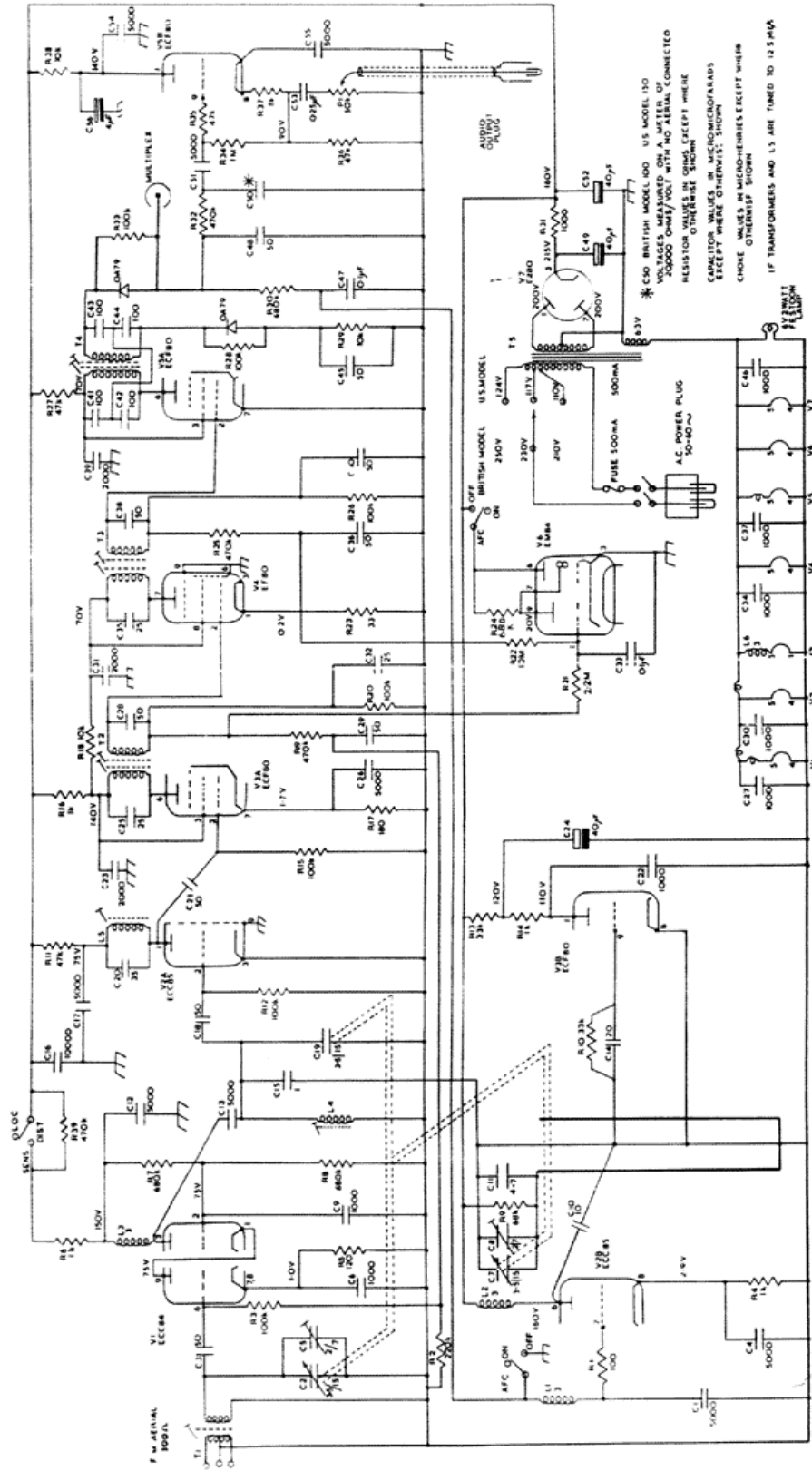

Leak Mk1 Trough-Line Tuner Circuit

**CIRCUIT DIAGRAM FM TUNER, SERIAL NO. 19062 AND ABOVE**

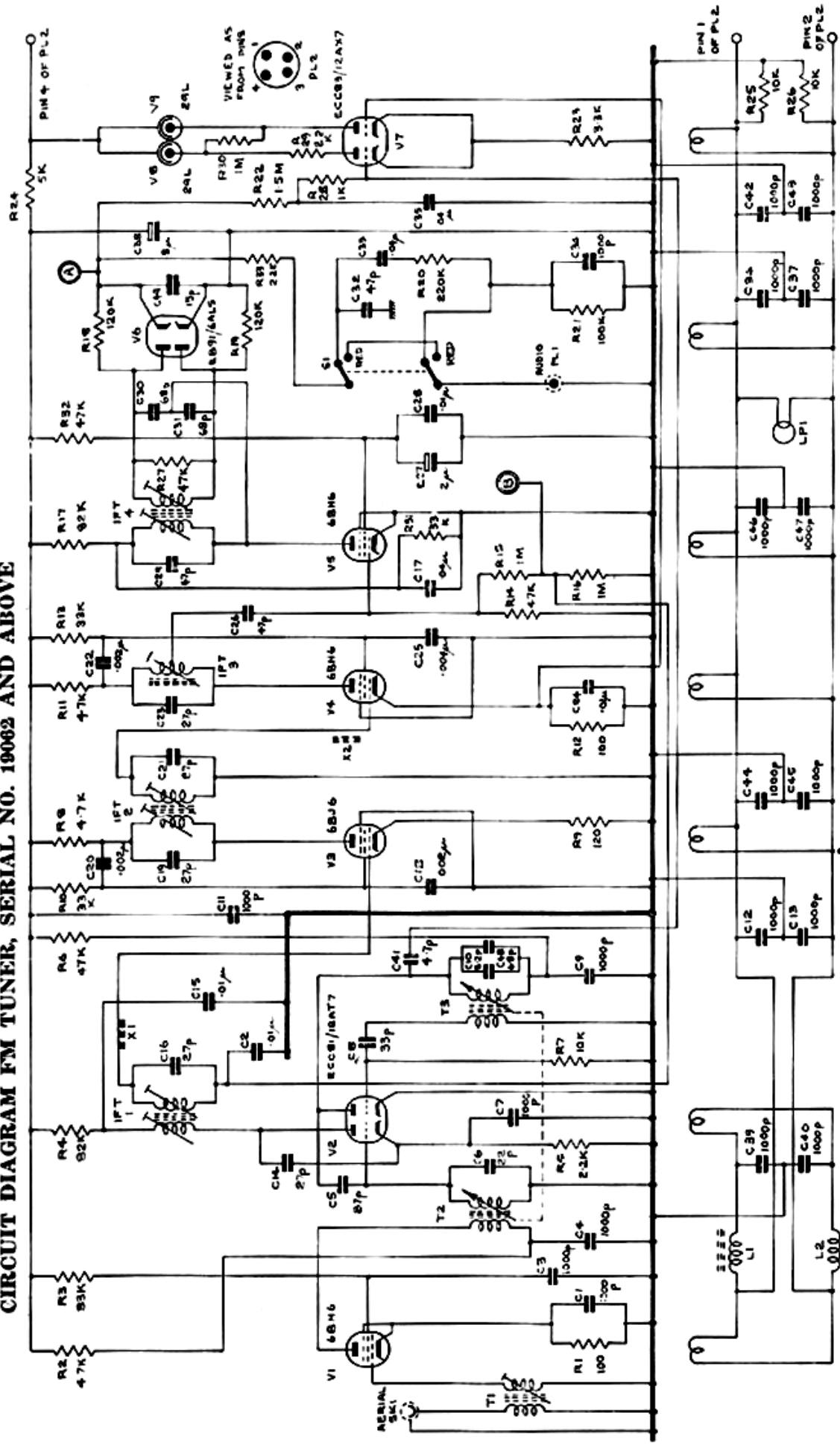

Drwg. B11765 Issue 2.

Quad FM1 Tuner Circuit



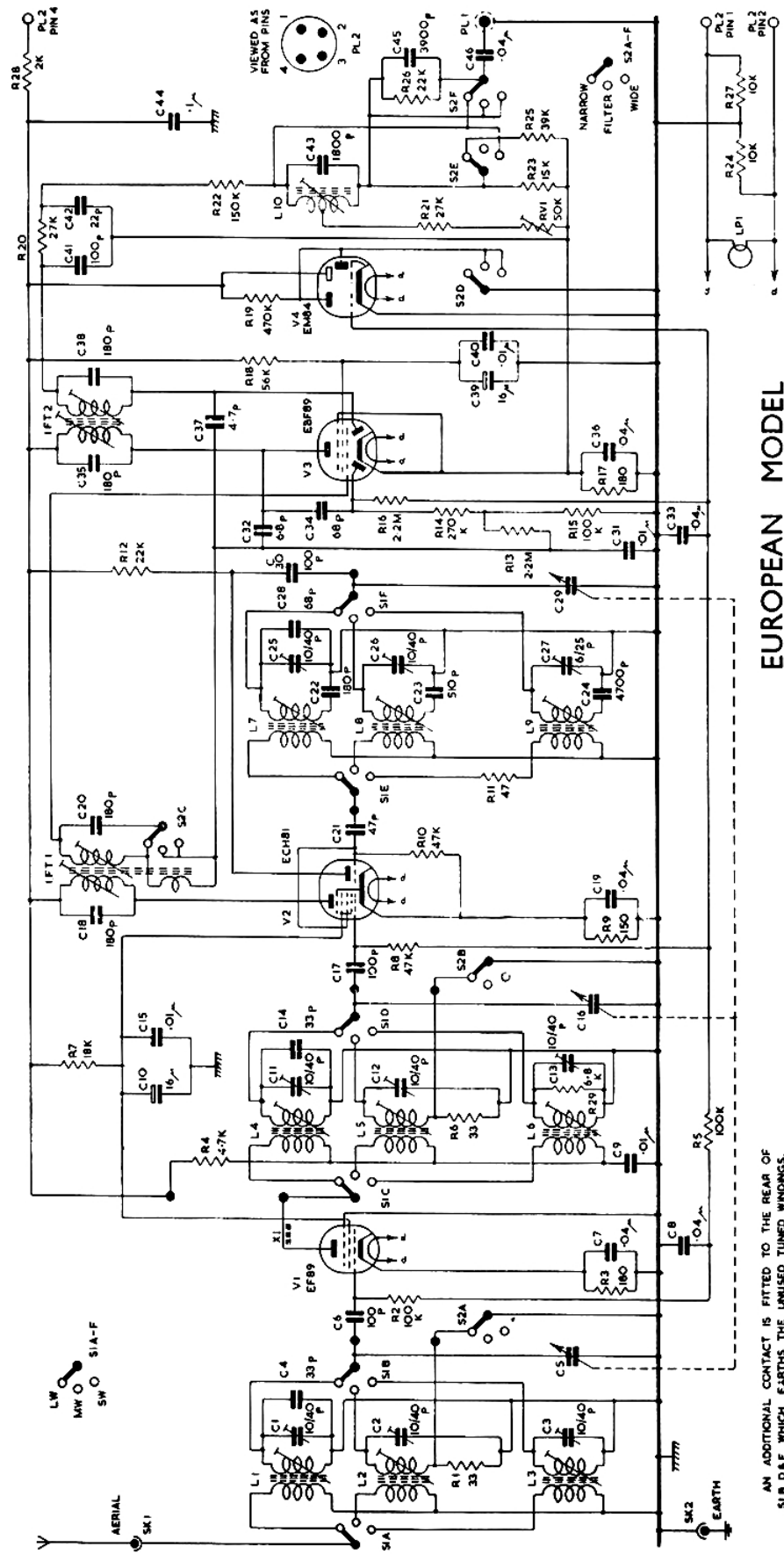

EUROPEAN MODEL

Quad AMII Circuit Diagram

AN ADDITIONAL CONTACT IS FITTED TO THE REAR OF S1B,D&E WHICH EARTHS THE UNUSED TUNED WINDINGS.